

ENGINEERING AND DESIGN

WATER SUPPLY, GENERAL CONSIDERATIONS

MOBILIZATION CONSTRUCTION

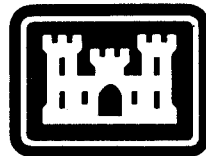

DEPARTMENT OF THE ARMY
CORPS OF ENGINEERS
OFFICE OF THE CHIEF OF ENGINEERS

DEPARTMENT OF THE ARMY
U.S. Army Corps of Engineers
Washington, D.C. 20314

EM 1110-3-160

DAEN-ECE-G

Engineer Manual
No. 1110-3-160

9 April 1984

Engineering and Design
WATER SUPPLY, GENERAL CONSIDERATIONS
Mobilization Construction

1. Purpose. This manual provides guidance in determining water requirements and in selection and planning of water supply systems for U.S. Army mobilization facilities.
2. Applicability. This manual is applicable to all field operating activities having mobilization construction responsibilities.
3. Discussion. Criteria and standards presented herein apply to construction considered crucial to a mobilization effort. These requirements may be altered when necessary to satisfy special conditions on the basis of good engineering practice consistent with the nature of the construction. Design and construction of mobilization facilities must be completed within 180 days from the date notice to proceed is given with the projected life expectancy of five years. Hence, rapid construction of a facility should be reflected in its design. Time-consuming methods and procedures, normally preferred over quicker methods for better quality, should be de-emphasized. Lesser grade materials should be substituted for higher grade materials when the lesser grade materials would provide satisfactory service and when use of higher grade materials would extend construction time. Work items not immediately necessary for the adequate functioning of the facility should be deferred until such time as they can be completed without delaying the mobilization effort.

FOR THE COMMANDER:

PAUL F. KAVANAUGH
Colonel, Corps of Engineers
Chief of Staff

DEPARTMENT OF THE ARMY
U. S. Army Corps of Engineers
Washington, D.C. 20314

EM 1110-3-160

Engineer Manual
No. 1110-3-160

9 April 1984

Engineering and Design
WATER SUPPLY, GENERAL CONSIDERATIONS
Mobilization Construction

	<u>Paragraph</u>	<u>Page</u>
CHAPTER 1. GENERAL		
Purpose and scope	1-1	1-1
Definitions	1-2	1-1
Environmental considerations. .	1-3	1-6
CHAPTER 2. WATER REQUIREMENTS		
Domestic requirements	2-1	2-1
Fire-flow requirements.	2-2	2-1
Irrigation.	2-3	2-2
CHAPTER 3. CAPACITY OF WATER-SUPPLY SYSTEM		
Capacity factors.	3-1	3-1
Use of capacity factor.	3-2	3-1
System design capacity.	3-3	3-1
Special design capacity	3-4	3-1
CHAPTER 4. SYSTEM PRESSURES		
Minimum pressures	4-1	4-1
Maximum pressures	4-2	4-1
Multiple pressure levels.	4-3	4-1
CHAPTER 5. WATER SYSTEM DESIGN PROCEDURE		
General	5-1	5-1
Selection of materials and equipment	5-2	5-1
Energy conservation	5-3	5-1
APPENDIX A. REFERENCES		A-1

CHAPTER 1

GENERAL

1-1. - Purpose and scope. This manual provides guidance in determining water requirements for Army mobilization installations and is applicable in selection and planning of supply systems. Other manuals in this series are:

EM 1110-3-161	Water Supply, Water Sources
EM 1110-3-162	Water Supply, Water Treatment
EM 1110-3-163	Water Supply, Water Storage
EM 1110-3-164	Water Supply, Water Distribution
EM 1110-3-166	Water Supply, Fire Protection

1-2. Definitions.

a. General definitions. The following definitions, relating to all water supplies, are established.

(1) Water works. All construction (structures, pipe, equipment) required for the collection, transportation, pumping, treatment, storage, and distribution of water.

(2) Supply works. Dams, impounding reservoirs, intake structures, pumping stations, wells, and other construction required for the development of a water supply source.

(3) Supply line. The pipeline from the supply source to the treatment works or distribution system.

(4) Treatment works. All basins, filters, buildings, and equipment for the conditioning of water to render it acceptable for a specific use.

(5) Distribution system. A system of pipes and appurtenances by which water is provided for domestic, industrial, and firefighting uses.

(6) Feeder mains. The principal pipelines of a distribution system.

(7) Distribution mains. The pipelines that constitute the distribution system except service lines.

(8) Service line. The pipeline extending from the distribution main to building served.

19 Apr 84

(9) Effective population. The resident personnel and dependents plus an allowance for nonresident personnel, derived by adding one-third of the population figure for nonresidents to the figure for residents.

$$\text{Effective Population} = \frac{\text{Nonresident Population} + \text{Resident Population}}{3}$$

(10) Backflow. The flow of any foreign liquids, gases, or other substances into the distributing pipelines of a potable supply of water from any source or sources not intended.

(11) Back-siphonage. The backing up, or siphoning, of a foreign liquid into a potable water system; this occurs when the potable water system, at any point or place, is at a pressure less than atmospheric, with an opening or break in the system, thereby drawing the foreign liquid toward the potable water.

(12) Capacity factor. The multiplier which is applied to the effective population figure to provide an allowance for reasonable population increase, variations in water demand, uncertainties as to actual water requirements, and for unusual peak demands whose magnitude cannot be accurately estimated in advance. The capacity factor varies inversely with the magnitude of the population in the water service area.

(13) Design population. The population figure obtained by multiplying the effective-population figure by the appropriate capacity factor.

$$\text{Design Population} = \text{Effective Population} \times \text{Capacity Factor}$$

(14) Required daily demand. The total daily water requirement. Its value is obtained by multiplying the design population by the appropriate per capita domestic water allowance and adding to this quantity any special industrial, aircraft-wash, irrigation, air-conditioning, or other demands. Other demands include the amount necessary to replenish in 48 hours the storage required for fire protection and normal operation. Where the supply is from wells, the quantity available in 48 hours of continuous operation of the wells will be used in calculating the total supply available for replenishing storage and maintaining fire and domestic demands and industrial requirements that cannot be curtailed.

(15) Peak domestic demand. For system design purposes, the peak domestic demand is considered to be the greater of:

(a) Maximum day demand, i.e., 2.5 times the required daily demand.

9 Apr 84

(b) The fire flow plus 50 percent of the required daily demand.

(16) Fire flow. The required number of gpm at a specified pressure at the site of the fire for a specified period of time.

(17) Fire demand. The required rate of flow of water in gpm during a specified fire period. Fire demand includes fire flow plus 50 percent of the required daily demand and, in addition, any industrial or other demand that cannot be reduced during a fire period. The residual pressure is specified for either the fire flow or essential industrial demand, whichever is higher. Fire demand must include flow required for automatic sprinkler and standpipe operation, as well as direct hydrant flow demand, when the sprinklers are served directly by the water supply system.

(18) Rated capacity. The rated capacity of a supply line, intake structure, treatment plant, or pumping unit is the amount of water which can be passed through the unit when it is operating under design conditions.

(19) Cross connection. Any physical connection which provides an opportunity for nonpotable water to contaminate potable water. Two types recognized are:

(a) A direct cross connection is a physical connection between a supervised, potable water supply and an unsupervised supply of unknown quality. An example of a direct cross connection is a piping system connecting a raw water supply, used for industrial fire fighting, to a municipal water system.

(b) An indirect cross connection is an arrangement whereby unsafe water, or other liquid, may be blown, siphoned, or otherwise diverted into a safe water system. Such arrangements include unprotected potable water inlets in tanks, toilets, and lavatories that can be submerged in unsafe water or other liquid. Under conditions of peak usage of potable water or potable water shutoff for repairs, unsafe water or other liquid may backflow directly or be back-siphoned through the inlet into the potable system. Indirect cross connections are often termed "backflow connections" or "back-siphonage connections." An example is a direct potable water connection to a sewage pump for intermittent use for flushing or priming.

(20) Elevated storage. That capacity or volume of a tank or reservoir above the minimum required hydraulic gradient. Elevated storage can be:

(a) Above natural grade - supported by a tower or pedestal where all storage is contained above ground except for water in feeder or supply pipes.

9 Apr 84

(b) At natural grade.

(c) Below natural grade.

(21) Ground storage. That capacity or volume of a tank or reservoir below the minimum required hydraulic gradient.

(22) Standpipe. A cylindrical tank whose height exceeds its diameter and is normally constructed of steel or reinforced concrete.

(23) Minimum required hydraulic gradient. That line (or plane) defining the minimum required residual pressures at given points during periods of peak demand.

(24) Uniformity coefficient. The ratio of the grain size of gravel or filter material for 40 percent retention to the grain size of gravel or filter material for 90 percent retention as measured by sieve analyses.

b. Ground water supply definitions. The meanings of several terms used in relation to wells and ground waters are shown in figure 1-1.

(1) Specific capacity. The specific capacity of a well is its yield per foot of drawdown and is commonly expressed as gpm per foot of drawdown.

(2) Aquifer. A porous, water-bearing geologic formation. The term is generally restricted to formations capable of yielding an appreciable supply of water.

(3) Confined aquifer. An aquifer that is surrounded by geologic formations of less permeable or impermeable material. An artesian well is one that taps a "confined aquifer."

(4) Unconfined aquifer. An aquifer whose upper limit is at atmospheric pressure. Unconfined aquifers are sometimes termed "water table" aquifers and are recharged principally by vertical percolation.

(5) Permeability coefficient. Permeability is a measure of the capacity of a porous formation for transmitting water. The standard permeability coefficient is the rate of flow of water at 60 degrees F., in gpd, through a cross section of 1 square foot, under a hydraulic gradient of unity.

(6) Transmissibility coefficient. The rate of flow in gpd through an aquifer's vertical section, whose height is the thickness of the aquifer and whose width is 1 foot, under a hydraulic gradient of unity, is the transmissibility coefficient. The transmissibility coefficient is, therefore, the product of the "standard permeability coefficient" and the aquifer thickness.

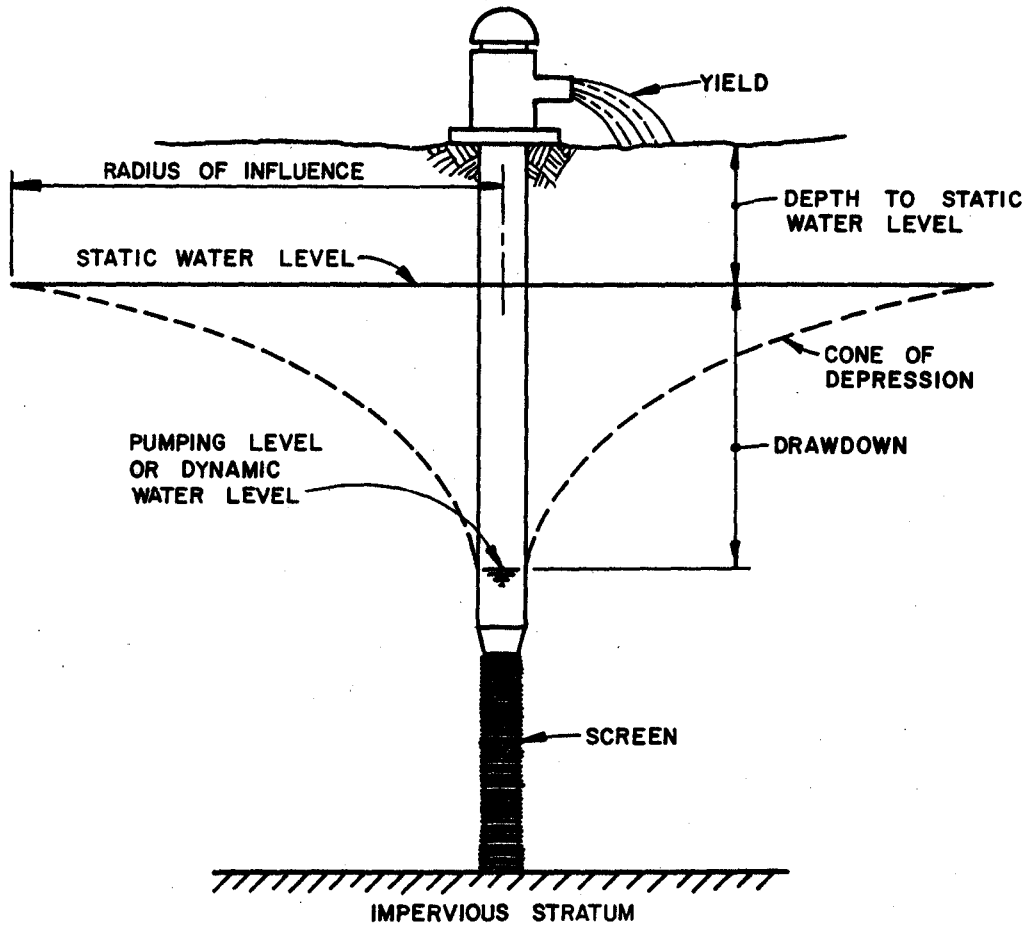

U. S. Army Corps of Engineers

FIGURE 1-1. DIAGRAMMATIC SECTION OF A WELL

9 Apr 84

(7) Vertical line shaft turbine pump. A vertical line shaft turbine pump is a centrifugal pump, usually having from one to 20 stages, used in wells. The pump is located at or near the pumping level of water in the well, but is driven by an electric motor or internal combustion engine on the ground surface. Power is transmitted from the motor to the pump by a vertical drive shaft.

(8) Submersible turbine pump. A submersible turbine pump is a centrifugal turbine pump driven by an electric motor which can operate when submerged in water. The motor is usually located directly below the pump intake in the same housing as the pump. Electric cables run from the ground surface down to the electric motor.

1-3. Environmental considerations. In general, the local and state environmental protection laws of the subject area will be applicable to the construction and operation of the mobilization facility. Agencies of these governing organizations should be contacted before construction begins to insure compliance with all applicable laws. For information on environmental policies, objectives, and guidelines, refer to AR 200-1.

CHAPTER 2

WATER REQUIREMENTS

2-1. Domestic requirements. The per-capita allowances, given in table 2-1, will be used in determining domestic water requirements. These allowances do not include special purpose water uses, such as industrial, aircraft-wash, air-conditioning, irrigation, or extra water demands at desert stations.

Table 2-1. Domestic Water Allowances for Army Mobilization Projects

	<u>Gallons/Capita Day¹</u>
Armored/Mechanical Divisions	150
Camps and Forts	150 ²
Hospital Units	600/Bed
Hotels	70
Depot, Industrial, Plant and Similar Projects	50 gallons/employee/8-hour shift; 150 gallons/capital/day for resident personnel

Notes:

¹The allowances given in this table include water used for laundries to serve resident personnel, washing vehicles, limited watering of planted and grassed areas, and similar uses. The per capita allowance for nonresidents will be one-third that allowed for residents.

²For populations under 300, 50 gallons/capita/day will be used for base camps and 25 gallons/capita/day for branch camps.

2-2. Fire-flow requirements. The system must be capable of supplying the fire flow specified plus any other demand that cannot be reduced during the fire period at the required residual pressure and for the required duration. The requirements of each system must be analyzed to determine whether the capacity of the system is fixed by the domestic requirements, by the fire demands, or by a combination of both. Where fire-flow demands are relatively high, or required for long duration, and population and/or industrial use is relatively low, the total required capacity will be determined by the prevailing fire demand. In some exceptional cases, this may warrant consideration of a special water system for fire purposes, separate, in part, or in whole, from the domestic system. However, such separate systems will be

9 Apr 84

appropriate only under exceptional circumstances and, in general, are to be avoided. Fire flows are to be as outlined in EM 1110-3-166.

2-3. Irrigation. In general, irrigation will not be considered but, some irrigation may be required. For example, sod planted for erosion control would require some watering. The allowances indicated in table 2-1 include water for limited watering of planted and grassed areas. However, these allowances do not include major lawn or other irrigation uses. Lawn irrigation provisions for facilities, such as temporary structures, in all regions will be limited to hose bibs on the outside of buildings and risers for hose connections. Underground sprinkler systems will not be considered.

a. Backflow prevention. Backflow prevention devices, such as a vacuum breaker or an air gap, will be provided for all irrigation systems connected to potable water systems.

b. Use of treated wastewater. Effluent from wastewater treatment plants can be used for irrigation when authorized. Only treated effluent having a detectable chlorine residual at the most remote discharge point will be used. Where state or local regulations require additional treatment for irrigation, such requirement will be complied with. The effluent irrigation system must be physically separated from any distribution systems carrying potable water. A detailed plan will be provided showing the location of the effluent irrigation system in relation to the potable water distribution system and buildings. Provisions will be made either for locking the sprinkler irrigation control valves or removing the valve handles so that only authorized personnel can operate the system. In addition, readily identifiable "non-potable" or "contaminated" notices, markings, or codings for all wastewater conveyance facilities and appurtenances will be provided. Another possibility for reuse of treated effluent is for industrial operations where substantial volumes of water for washing or cooling purposes are required. For any reuse situation, great care must be exercised to avoid direct cross connections between the reclaimed water system and the potable water system.

9 Apr 84

CHAPTER 3

CAPACITY OF WATER-SUPPLY SYSTEM

3-1. - Capacity factors. Capacity factors, as a function of effective population, are shown in table 3-1, as follows:

Table 3-1. Capacity Factors

<u>Effective Population</u>	<u>Capacity Factor</u>
5,000 or less	1.50
10,000	1.25
20,000	1.15
30,000	1.10
40,000	1.05
50,000 or more	1.00

3-2. Use of capacity factor. The capacity factor will be used in planning water supplies for all projects, including general hospitals. The proper capacity factor as given in table 3-1 is multiplied by the effective population to obtain the design population. Arithmetic interpolation should be used to determine the appropriate capacity factor for intermediate project population. (For example, for an effective population of 7,200 in interpolation, obtain a capacity factor of 1.39.) Capacity factors will be applied in determining the required capacity of the supply works, supply lines, treatment works, principal feeder mains, and storage reservoirs. Capacity factors will not be used for hotels and similar structures that are acquired or rented for hospital and troop housing. Capacity factors will not be applied to fire flows, irrigation requirements, or industrial demands.

3-3. System design capacity. The design of elements of the water supply system, except as noted in paragraph 3-2, should be based on the design population.

3-4. Special design capacity. Where special demands for water exist, such as those resulting from unusual fire fighting requirements, irrigation, industrial processes, and cooling water usage, consideration must be given to these special demands in determining the design capacity of the water supply system.

CHAPTER 4

SYSTEM PRESSURES

4-1. - Minimum pressures. Water distribution systems, including pumping facilities and storage tanks or reservoirs, should be designed so that water pressures of at least 40 psi at ground level will be maintained at all points in the system, including the highest ground elevations in the service area. Minimum pressures of 30 psi, under peak domestic flow conditions, can be tolerated in small areas as long as all peak flow requirements can be satisfied. During firefighting flows, water pressures should not fall below 20 psi at the hydrants for new construction and not below 10 psi at existing hydrants when affected by new water line construction.

4-2. Maximum pressures. Maximum water pressures in distribution mains and service lines should not normally exceed 75 psi at ground elevation. Static pressures up to 100 psi can be tolerated in distribution systems in small, low-lying areas. Higher pressures require pressure reducing valves on feeder mains or individual service lines to restrict maximum service pressures to 75 psi.

4-3. Multiple pressure levels. If an extensive area has pressures higher than 75 psi or lower than 40 psi under a single pressure level configuration, it may be appropriate to divide the system into two or more separate areas each having different pressure levels. Within each level, pressures within the distribution system should range from 40 to 75 psi at ground elevation.

CHAPTER 5

WATER SYSTEM DESIGN PROCEDURE

5-1. General. Water supply is an essential feature of any large project and water system planning should be coordinated with the design of the project elements in order to insure orderly progress toward project completion. Major elements of the water system, such as supply works, usually can be located and designed in advance of detailed project site planning. On the other hand, the design of the distribution system must be deferred until completion of topographic surveys and the development of the final site plan.

5-2. Selection of materials and equipment. Selection of materials, pipe, and equipment should be consistent with system operating and reliability considerations, energy conservation, and the expected useful life of the project. To avoid delivery delays, standard equipment that can be supplied by several manufacturers should be specified. Delivery schedules must be investigated prior to purchase commitments for mechanical equipment.

5-3. Energy conservation. For the water supply system considered, energy requirements will be clearly identified and the design analysis will include consideration of all energy conservation measures consistent with system adequacy and reliability.

APPENDIX A

REFERENCES

Government Publications.

Department of the Army.

AR 200-1	Environmental Quality - Environmental Protection and Enhancement.
EM 1110-3-161	Water Supply, Water Sources.
EM 1110-3-162	Water Supply, Water Treatment.
EM 1110-3-163	Water Supply, Water Storage.
EM 1110-3-164	Water Supply, Water Distribution.
EM 1110-3-166	Water Supply, Fire Protection.