

CECW-ED Engineer Manual 1110-2-2007	Department of the Army U.S. Army Corps of Engineers Washington, DC 20314-1000	EM 1110-2-2007 30 April 1995
	Engineering and Design STRUCTURAL DESIGN OF CONCRETE LINED FLOOD CONTROL CHANNELS	
	Distribution Restriction Statement Approved for public release; distribution is unlimited.	

DEPARTMENT OF THE ARMY
U.S. Army Corps of Engineers
Washington, DC 20314-1000

EM 1110-2-2007

CECW-ED

Manual
No. 1110-2-2007

30 April 1995

Engineering and Design
STRUCTURAL DESIGN OF CONCRETE LINED
FLOOD CONTROL CHANNELS

1. Purpose. This manual provides guidance for the design of reinforced, concrete lined flood control channels which convey rapid and tranquil storm water flows to prevent flooding. This guidance presents provisions for coordinating the disciplines involved in the design of channels, selecting channel type, and identifying the critical aspects of designs which require quality assurance inspection during construction. Channel design involves determining the overall channel configuration including appurtenant structures, designing reinforced concrete structures and pavement or concrete lining, determining type and location of joints, designing subdrainage systems, and designing appropriate safety features.

2. Scope. This guidance addresses trapezoidal and rectangular flood control channels lined with reinforced concrete. Guidance is not included for the design of channel linings formed by gabions, riprap, shotcrete, gunite, or grouted mattresses.

3. Applicability. This guidance applies to all HQUSACE elements, major subordinate commands, districts, laboratories, and field operating activities having civil works responsibilities.

FOR THE COMMANDER:

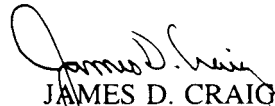
JAMES D. CRAIG
Colonel, Corps of Engineers
Chief of Staff

CECW-ED

Manual
No. 1110-2-2007

30 April 1995

**Engineering and Design
STRUCTURAL DESIGN OF CONCRETE LINED
FLOOD CONTROL CHANNELS**

Table of Contents

Subject	Paragraph	Page	Subject	Paragraph	Page
Chapter 1			Drainage Provisions	3-3	3-1
Introduction			Continuously Reinforced Concrete		
Purpose and Scope	1-1	1-1	Paving	3-4	3-2
Applicability	1-2	1-1	Construction Joints	3-5	3-3
References	1-3	1-1	Expansion Joints	3-6	3-4
Design Philosophy	1-4	1-1	End Anchorage	3-7	3-4
Coordination	1-5	1-1	Cutoff Walls	3-8	3-4
Channel Section	1-6	1-2	Intersecting Channels	3-9	3-4
Safety Provisions	1-7	1-2	Deficiencies in Past Designs of		
Aesthetic Provisions	1-8	1-2	Paved Trapezoidal Channels	3-10	3-5
Relationship between Design			Drainage Layer Construction	3-11	3-5
Assumptions and Construction			Maintenance Considerations	3-12	3-5
Practices	1-9	1-2	Repair of Damaged Paving	3-13	3-6
Computer Programs for					
Structural Design	1-10	1-2	Chapter 4		
Chapter 2			Special Design Considerations for		
General Design Considerations			Rectangular Channels Lined with		
General	2-1	2-1	Retaining Wall Structures		
Selection of Channel Type	2-2	2-1	General	4-1	4-1
Reinforced Concrete Structures	2-3	2-1	Retaining Wall Types	4-2	4-1
Drainage Provisions	2-4	2-5	Channel Bottoms	4-3	4-1
Vehicular Access Ramps	2-5	2-6	Joints in Retaining Walls	4-4	4-1
Control of Water During			Drainage Provisions	4-5	4-1
Construction	2-6	2-6	Structural Design	4-6	4-2
Maintenance During			Special Considerations During		
Operation	2-7	2-6	Construction	4-7	4-4
Protection of Private					
Property	2-8	2-6	Chapter 5		
Chapter 3			Special Design Considerations		
Special Design Considerations for			for Rectangular Channels Lined		
Paved Trapezoidal Channels			with U-frame Structures		
Introduction	3-1	3-1	General	5-1	5-1
Constructibility of Paving Slabs on			Foundation Considerations	5-2	5-1
Sloped Sides of Channels	3-2	3-1	Joints in Concrete	5-3	5-1
			Drainage Provisions	5-4	5-1
			Structural Design	5-5	5-1

Subject	Paragraph	Page	Subject	Paragraph	Page
Special Considerations during Construction	5-6	5-2	Appendix C Drainage System Designs for U-frame and Trapezoidal Channels		
Appendix A References		A-1			C-1
Appendix B Computer Programs		B-1	Appendix D Equations for Continuously Rein- forced Concrete Pavement		
					D-1

Chapter 1 Introduction

1-1. Purpose and Scope

a. Purpose. This manual provides guidance for the design of reinforced, concrete lined flood control channels which convey rapid and tranquil storm water flows to prevent flooding. This guidance presents provisions for coordinating the disciplines involved in the design of channels, selecting channel type, and identifying the critical aspects of designs which require quality assurance inspection during construction. Channel design involves determining the overall channel configuration including appurtenant structures, designing reinforced concrete structures and pavement or concrete lining, determining type and location of joints, designing subdrainage systems, and designing appropriate safety features.

b. Scope. This guidance addresses trapezoidal and rectangular flood control channels lined with reinforced concrete. Guidance is not included for the design of channel linings formed by gabions, riprap, shotcrete, gunite, or grouted mattresses.

(1) Trapezoidal channels. Trapezoidal channels have sloped sides and are formed by excavating in situ materials. The sloped sides and channel bottom may require paving for protection, depending on the stability of the sides and the resistance of the in situ materials to erosion.

(2) Rectangular channels. Rectangular channels have vertical or near vertical sides which are formed with reinforced concrete retaining walls, I-walls, or U-frame structures. The channel bottom may be paved or unpaved depending on the resistance of the in situ material to erosion.

1-2. Applicability

This guidance applies to all HQUSACE elements, major subordinate commands, districts, laboratories, and field operating activities having civil works responsibilities.

1-3. References

Required and related publications are listed in Appendix A.

1-4. Design Philosophy

Flood control channels are constructed for the purpose of conveying heavy storm water flows through and from areas which would otherwise be inundated, usually resulting in property damages and loss of life. Typically, these projects are owned and maintained by local sponsors. These channels usually: are the primary feature of local flood protection projects, extend for great distances, require significant construction costs due to their extensiveness, and present extreme consequences should failure occur. Therefore, channel design solutions should be developed in a logical and conservative manner which provides for economical construction and serviceability and ensures functional and structural integrity.

1-5. Coordination

Although this guidance pertains primarily to the structural design aspects of flood control channel design, close coordination with other design disciplines and the local sponsor is required. Other disciplines involved in the design are hydrologic, hydraulic, concrete and materials, geotechnical, environmental, and construction. Some of the critical aspects of the design process which require coordination are:

a. Estimates of design slope and runoff volumes, selection of channel cross-sectional area, and location of required energy dissipation and juncture structures.

b. Design water surface elevations.

c. Topography of area containing the channel alignment and existing elements, structures, utilities, etc.

d. Preliminary estimates of geotechnical data, surface and subsurface conditions, and location of existing structures of utilities.

e. Evaluation of technical and economic feasibility of alternative designs.

f. Refinement of the preliminary design to reflect the results of more detailed site exploration, laboratory testing, and numerical testing and analyses.

1-6. Channel Section

The proper cross section for a reach of channel is one that provides adequate hydraulic capacity at the minimum cost. Economic considerations for selecting the channel section include the costs of design and construction, right-of-way, required relocations, and maintenance and operation. A trapezoidal channel is usually the most economical channel when right-of-way is available and is, therefore, the more commonly used channel section. A rectangular channel may be required for channels located in urban areas where the right-of-way is severely restricted or available only at a high cost.

1-7. Safety Provisions

Channel designs should include safety provisions for the needs of the public and operations personnel. Local sponsors are responsible for the safe operation of channels, and designers should coordinate designs with the sponsor so that appropriate provisions are incorporated to ensure safe operation of the project. Railing or fencing should be provided on top of rectangular channel walls and walls of chutes or drop structures for public protection. Ladders should be provided on the sides of rectangular channel walls and steps provided on the sloped paving of trapezoidal channels to provide safe access for operations personnel.

1-8. Aesthetic Provisions

The merits of incorporating environmental quality into channel design have been established. EM 1110-2-38 and EM 1110-2-301 provide guidance for channel alignment, landscaping, and aesthetic treatment of channel linings.

1-9. Relationship between Design Assumptions and Construction Practices

The designer should identify the design assumptions, details, and specification requirements which are essential

to design integrity. These items should receive assurance inspection during construction to assure that actual field conditions and construction practices are in compliance with the design assumptions and specification requirements. Some assurance inspection items for channels are listed below. These items should be adjusted as appropriate for the particular design.

- a.* Subgrade preparation (materials, compaction, and finished grade).
- b.* Reinforcing steel (materials and placement).
- c.* Concrete (materials, strength, mixing, placing, thickness, and other dimensions).
- d.* Waterstops and joints (type and installation).
- e.* Subdrainage system (pipe material, valves types, filter materials, and other installation requirements).

1-10. Computer Programs for Structural Design

A listing and description of some of the current computer programs which are suitable for the structural design of elements of rectangular channels are given in Appendix B. Corps programs and user's guides describing program capabilities may be obtained from:

U.S. Army Engineer Waterways Experiment Station
ATTN: CEWES-IM-DS/ECPL
3909 Halls Ferry Road
Vicksburg MS 39180-6199

Chapter 2 General Design Considerations

2-1. General

This chapter provides general considerations for selecting the appropriate channel type and defining the requirements for executing the selected design.

2-2. Selection of Channel Type

Paragraph 1-6 identifies the hydraulic capacity as the primary functional consideration and the costs of right-of-way, relocations, construction, and operation as economic considerations for selecting channel type. Existing site developments, existing geophysical site conditions, and performance or service requirements impact the selection of channel type and the resulting construction costs. The construction cost of trapezoidal channel sections is less than that of rectangular sections. Generally, the lowest cost of erosion protection is sod, and the cost increases with riprap protection and even more when reinforced concrete paving is used. Typical trapezoidal channel types are shown in Figure 2-1.

a. Existing site developments. Existing roads, bridges, and buildings in highly developed areas often dictate the channel type and channel configuration. The more expensive rectangular channel sections, discussed in Chapters 4 and 5, are commonly required in areas where the right-of-way is highly restricted. Typical rectangular channel types are shown in Figure 2-2.

b. Geophysical site conditions. Existing geophysical site conditions including the characteristics of in situ materials, depth of frost penetration, ground water levels, subsidence potential, faulting, and earthquake potential impact design solutions. The strength and erodability of in situ materials usually dictate whether a channel lining is required. Reinforced concrete walls located in seismic zones should be designed and constructed to resist the earthquake forces. High ground water levels increase the requirements for subdrainage systems.

c. Service requirements.

(1) Top of channel. The project's level of protection is selected by a comparison of hydraulic flow line calculations, construction costs for various channel sizes, and economic benefits. These calculations are based on risk and uncertainty principles. The selected level of

protection will define the nominal elevation of the top of the channel. This elevation may be modified locally to account for flow disturbances from causes such as bridge piers, side channels, or channel bends.

(2) Channel flow. Channel flow patterns and changes in the water surface at bends in the channel should be considered in determining the channel cross section and overall configuration requirements.

(a) Pilot channels. Pilot channels are constructed in the bottom of flat bottom channels which carry low flows except during floods. These channels confine low flows thereby maintaining higher velocities which may decrease the amount of sediment and trash deposits. The success of pilot channels has been varied. Experience has shown that sediment deposits occur in a pilot channel when the channel slope is not sufficient to maintain the velocities required to transport the sediments. An alternate design to a pilot channel is a V-shaped channel bottom. These channel configurations are shown in Figure 2-1.

(b) Channel linings. Channel lining requirements are dependent upon the maximum velocity of flows and the resistance of the in situ materials to erosion. The quality of contained waters may affect the design of concrete linings. The presence of salts, sulfates, industrial wastes, and other abrasive or scouring materials sometimes requires thicker concrete lining sections with increased reinforcement cover. Mix design revisions using appropriate admixtures should be considered as an alternative to increasing the lining thickness.

(c) Supplementary structures. Supplementary or appurtenant structures such as weirs, tunnels, culverts, inverted siphons and chutes, sediment or debris basins, and drop structures are often required. These appurtenant features are designed to satisfy the channel flow conditions.

(d) Terminal structures. When the downstream end of a channel lining project terminates in erodible material, some type of energy dissipation treatment, such as stilling basin, drop structure, or riprap, is needed.

2-3. Reinforced Concrete Structures

a. Materials. Materials for the construction of the reinforced concrete structures of concrete lined flood control channels shall comply with current Corps of Engineers guide specifications.

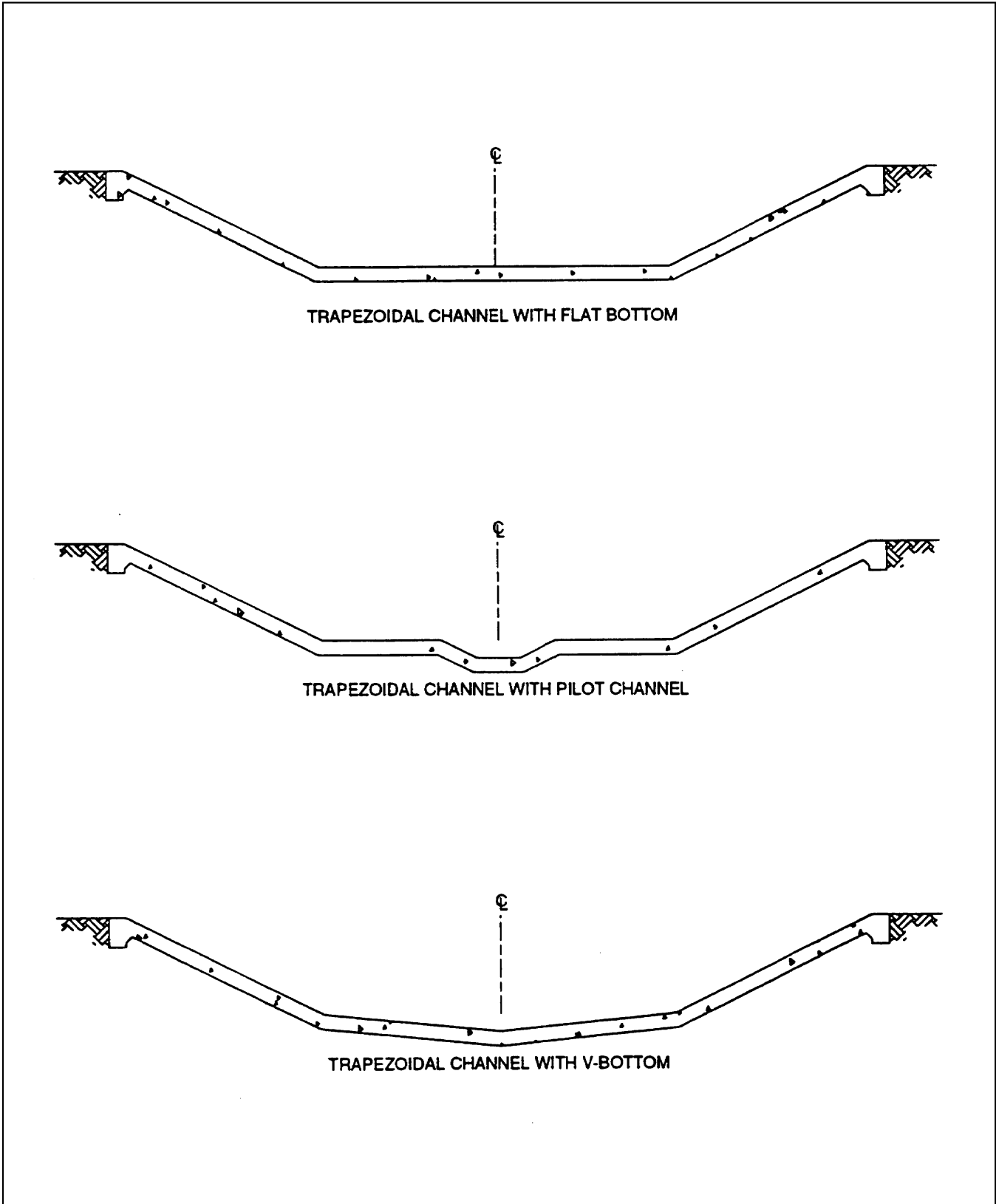

Figure 2-1. Trapezoidal channel sections

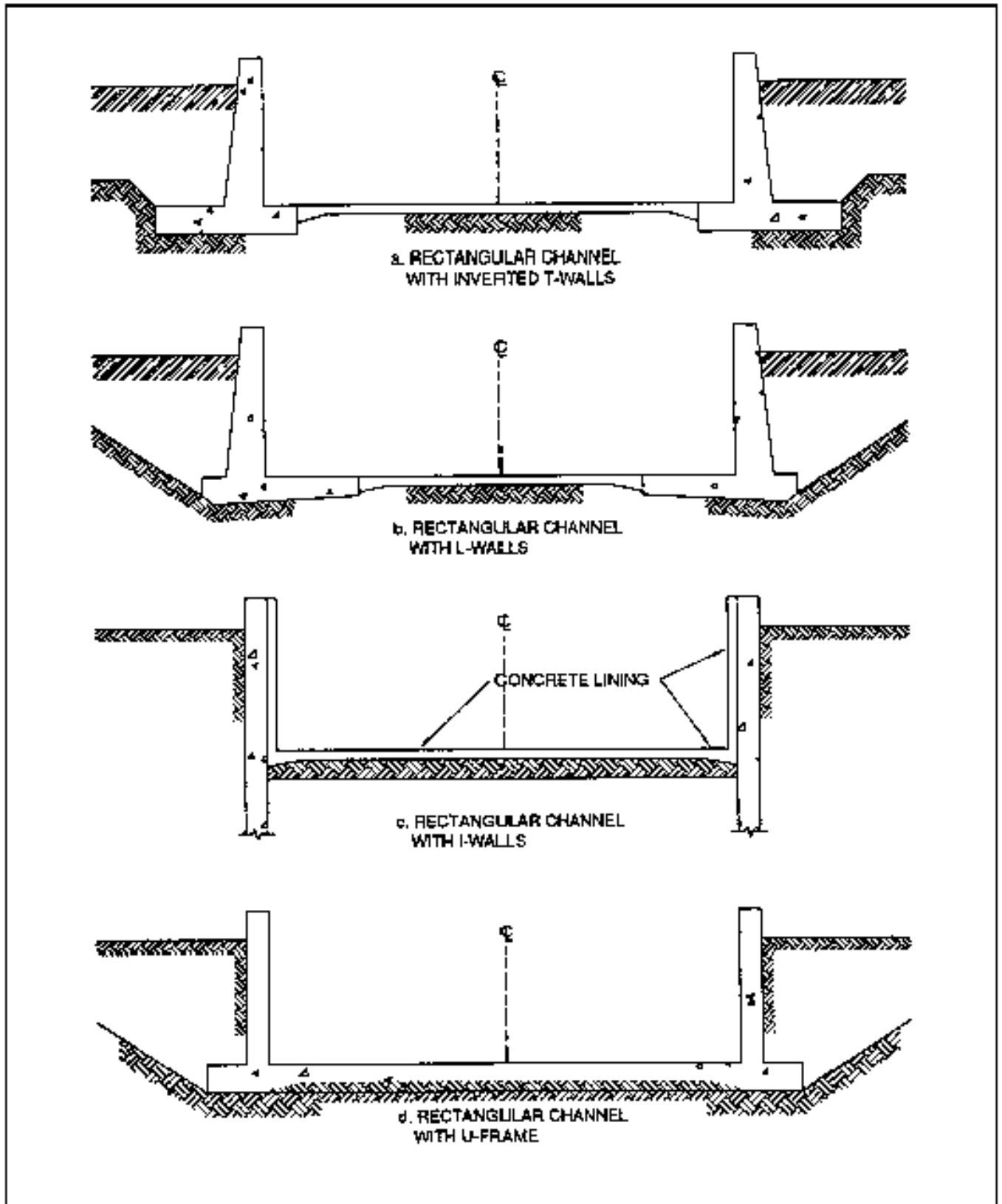

Figure 2-2. Rectangular channel sections

(1) Concrete. Guidance for concrete materials and mixture proportioning is given in EM 1110-2-2000. Typically, a compressive strength of 25 MPa (3,000 psi) at 28 days is used. Higher strengths may sometimes be justified for retaining walls, I-walls, or U-frame structures. Air-entrained concrete should be used when freeze-thaw conditions are anticipated. Microsilica, fly ash, aggregate hardness, etc., should be considered as improvements in resistance to abrasion, when required. Type II cement should be used when sulfates are present in moderate concentration.

(2) Reinforcement. Steel bars shall be American Society for Testing and Materials (ASTM) Grade 60, deformed, cut lengths, or fabricated mats. Steel welded wire fabric shall be deformed wire produced from rods or bars that have been hot rolled. Consideration should be given to the use of a lower-permeability concrete and epoxy coated or galvanized reinforcement steel in areas where channel linings will be subjected to highly corrosive constituents such as saltwater or sanitary and industrial wastes.

(3) Joint filler. Joint filler shall be preformed sponge rubber.

(4) Joint sealant. Joint sealant shall be cold applied, multicomponent, and elastomeric. The sealant is installed in joints to prevent weathering of joint filler and is subjected to cyclic tension and compression loading as the temperature changes.

(5) Waterstops. Waterstops should be installed in joints of concrete sections when watertightness is desired. Guidance for use of waterstops is given in EM 1110-2-2102 and EM 1110-2-2502. Waterstops in joints which may experience appreciable movements should be rubber or polyvinyl chloride.

b. Structural design loadings. The forces acting on the structures and the weight of structures should be defined to perform the stability analyses and the design of the reinforced concrete sections of the structures. Some of the applied forces may be indeterminate in nature, and the designer must assume their location, direction, and magnitude. Assumptions should be based on available criteria, loading conditions, and the application of engineering expertise and judgment. Unsymmetrical loading, resisted by sliding friction or passive pressure, should be analyzed.

(1) Earth pressures. Earth pressures on walls of rectangular channels should be determined by using the

criteria given in EM 1110-2-2502 and ETL 1110-2-322 for T-type retaining walls and EM 1110-2-2504 for I-walls. Free-draining granular materials should be used for backfill behind walls to reduce the lateral earth pressure, decrease pressures due to frost action, minimize pressure increases from in situ materials having expansive characteristics, and increase the effectiveness of the drainage system.

(2) Hydrostatic pressures. Hydrostatic horizontal pressure behind walls and uplift pressure under paving slabs should be determined. Uplift pressures should be determined for the steady-state seepage and drawdown conditions. The magnitude of hydrostatic pressures may be reduced by installing drainage systems as discussed in paragraphs 2-4, 3-3, 4-5, and 5-4.

(3) Earthquake forces. Seismic forces for vertical walls of rectangular channels may be significant and should be determined using criteria given in ER 1110-2-1806 and EM 1110-2-2502. Seismic forces cause only small increases in earth and hydrostatic pressures on paving slabs and should be ignored.

(4) Wind. Reference should be made to EM 1110-2-2502 for wind loads on walls but these are usually negligible. Wind loads on paving slabs should be ignored.

(5) Surcharge. Surcharge loads from construction, operations and maintenance equipment, and highway or street vehicles should be included as appropriate. Criteria for determining surcharge loads are given in EM 1110-2-2502.

c. Constructibility. The dimensions of the concrete structures of flood control channels should be such that the reinforcement, embedded metal, and concrete can be properly placed. The thickness of the top of walls greater than 8 ft in height and footings supporting such walls shall not be less than 12 in. to facilitate concrete placement. The thickness of the top of walls less than 8 ft in height and containing only one layer of reinforcement may be decreased to 8 in. Walls should be designed for construction simplicity and maximum reuse of concrete forms. Dimensions of monoliths, independently stable units of concrete structures, should be selected to allow practical volumes of concrete placements.

d. Joints in concrete. Joints are provided in the reinforced concrete structures of flood control channels to divide them into convenient working units and to allow for expansion and contraction. The number of joints

should be kept to a minimum to reduce construction and maintenance costs. There are no exact rules for determining the number and location of joints required in structures. The structural design requirements, overall dimensions, and form requirements should be considered to efficiently locate the joints. Guidance on expansion and contraction joints of retaining walls is given in EM 1110-2-2502. The location of all joints should be shown in the drawings.

(1) Construction joints. Construction joints are used to divide structures into convenient working units and to provide bonded joints where concrete pours have been terminated. Keys are not recommended for horizontal construction joints because they are difficult to construct of sound concrete and to adequately clean for good bonding. Reinforcement should be continuous through construction joints.

(2) Contraction joints. Contraction joints are used to divide structures into independently stable, constructible monoliths to control cracking due to curing, shrinkage, and temperature differentials. The spacing of contraction joints is dependent upon the characteristics of foundation materials, climatic conditions, channel flow patterns, and other geophysical site conditions. Reinforcement should not be continuous through contraction joints.

(3) Expansion joints. Expansion joints are used to prevent crushing or spalling of concrete at abutting surfaces due to thermal expansion or differential movement resulting from settlement or applied loads. Expansion joints are commonly located at changes or junctures in structures. Reinforcement should not be continuous through expansion joints.

2-4. Drainage Provisions

Drainage systems should be provided to control excessive hydrostatic pressures acting on the concrete structures of lined flood control channels where the permanent water table is above the channel invert. These systems should also be provided where the temporary water table is expected to be above the channel invert due to local ponding or seasonal variations.

a. Drainage systems. Drainage systems used in past designs include open, closed, and weep-hole systems. Open drainage systems consist of collector drains which drain through weep holes in the channel lining. The collector drains are encased with a graded filter to prevent blockage of the drain or removal of the foundation material. Closed drainage systems consist of drainage

blankets, collector drains, collector manholes, and outlet drains which drain into the channels. The outlet drains are provided with check valves to prevent the backflow of water from the channels into the drainage system. Weep-hole systems have been used for paving on rock foundations and usually consist of a system of holes drilled in the rock and weep holes in the paving slab. These systems are subject to clogging and require routine maintenance. Channel water will tend to backflow into the system and deposit silt during high channel water levels. Open systems are obviously more susceptible to clogging because they do not restrict backflow and should only be used for noncritical channels, side channels, and small channels (about 3 m (10 ft) maximum in bottom width and depth, respectively). Closed systems shall be used for critical and large channels of which the continuous relief of hydrostatic pressures is critical to channel performance.

b. System selection. The investigations, analyses, and conclusions made in the selection of a drainage system for a flood control channel should be thoroughly documented in the project design memorandum. This documentation should include, but not be limited to, analyses of the geological and geohydrological investigation data, suitability of the system type for the specific site, and suitability of the system type for the operational requirements.

c. System design investigation. Design of a drainage system requires information on subsurface soils and/or rock and ground water conditions along the channel area and also information on the characteristics of streamflow. A general understanding of the geology and geohydrology of the area should be obtained. Specific project data include information on the extent, thickness, stratification, and permeability of subsurface materials along the channel and information on ground water levels, their variations, and the factors which influence the variations. Information is also needed on stream stage variations and related ground water fluctuations so that the design differential head condition can be developed.

d. System design. The design of a drainage system should be based on the results of seepage analyses performed to determine the required discharge capacity of the system. The design includes determination of the drainage blanket permeability and thickness requirements, collector drain spacing and size, and manhole spacing and location. Appendix C provides example seepage analyses and drainage system designs. Contract plans and specifications should require modification of the drainage system to alleviate perched water conditions encountered during

construction. Drainage systems for trapezoidal channels are described in paragraph 3-3 and illustrated in Plate 1. Drainage systems for rectangular channels are described in paragraphs 4-5 and 5-4 and illustrated in Plate 2.

e. System effectiveness. As discussed in paragraph 2-4a, drainage systems require routine cleaning and maintenance to relieve clogging. The need for routine operation and maintenance activities such as the control of aquatic weeds and silt removal should be addressed in the design. Experience has shown that many local flood protection projects are not adequately maintained. Therefore, unrelieved clogging can be expected to occur, thereby decreasing the effectiveness of the systems and resulting in increased hydrostatic pressures. Presently, precise information on the extent of loss of effectiveness of drainage systems during the life of projects is not available. However, since it is known that some loss of effectiveness does occur, channel lining designs should reflect possible increased hydrostatic pressures resulting from some loss in effectiveness of the drainage system during the life of the project. Without supporting data, drains may be assumed to be 75 percent effective. The criteria used in the design for determining the extent of loss of drainage system effectiveness should be thoroughly documented.

2-5. Vehicular Access Ramps

Vehicle access ramps are provided to permit vehicular access during the construction and maintenance of projects. These ramps should enter the channel from an upstream to downstream direction. The number of ramps should be held to a minimum and each ramp carefully located so that its effect on the hydraulic efficiency and flood surface profile is minimized.

2-6. Control of Water During Construction

The channel flows which should be controlled during construction are primarily local runoff and a selected storm runoff. This flow must be controlled by diversion, pumping, or phasing of the construction. One side of the

channel is often constructed while providing for diversion of the water on the other side of the channel. After completion of the first side of the channel, flows are diverted to the completed side while completing the opposite side. Contract plans and specifications shall define the level of flood protection for which the construction contractor is responsible. The contractor should be responsible for the means of controlling the water, subject to approval by the government contracting officer.

2-7. Maintenance During Operation

Proper maintenance of flood control channels is essential to satisfactory performance. This requires periodic inspection of the channels, including the concrete linings, appurtenant concrete structures, and the subdrainage system. Current Corps Operations & Maintenance (O&M) provisions require that flood control projects be inspected periodically. The frequency of project inspections and other operation and maintenance requirements shall be identified in the project O&M Manual. Any deficiencies critical to the function of the project should be corrected with urgency. Broken concrete and cracks in the concrete which are wide enough to cause concern should be repaired. Subdrain systems that are clogged shall be cleaned.

2-8. Protection of Private Property

Certain reaches of the channels often require protection or underpinning of private property during channel construction. Shoring concepts often include drilled tangent pier walls or steel H-pile (soldier pile) walls with lagging. The wall system must control lateral deflections and prevent loss of ground. These wall systems are sometimes designed with anchor ties or struts. Other less expensive methods of shoring may be acceptable, depending upon the closeness and criticality of the property to be protected. The effects of construction vibrations and the removal or loss of lateral resistances should be evaluated. The effects of construction vibrations may be evaluated using the criteria developed by Woods and Jedele (1985) in Appendix A.

Chapter 3 Special Design Considerations for Paved Trapezoidal Channels

3-1. Introduction

a. Background. Corps practice, prior to the 1960's, was to employ concrete pavement with expansion and contraction joints for paved trapezoidal channels. Typically, the channel pavements contained light reinforcement. Many types of joints and a wide variety of joint spacings were used. The experience with these channels shows that substantial joint maintenance is required. Routine cleaning and replacement of the joint sealing compounds and expansion joint materials is needed. Pavement blowups result from improperly constructed joints and an infiltration of incompressible materials into the joints. Some of these jointed pavements have also developed uncontrolled cracks away from the joints that require repair. Many states were eliminating transverse joints and constructing continuously reinforced concrete highway pavements during the 1950's. By the 1960's, continuously reinforced concrete pavement was no longer considered experimental, and the Corps began to use this type pavement for trapezoidal channels.

b. Pavement type. When concrete paving is used for trapezoidal channels in soil, it should be continuously reinforced concrete pavement (CRCP). CRCP is concrete pavement with continuous longitudinal and transverse reinforcement achieved by lapping the reinforcing bars. There are no control joints, and the continuous reinforcement is used to control cracks which form in the pavement due to volume changes in the concrete and foundation friction. Construction joints must be provided in CRCP at ends of construction pavements. Slab continuity is provided by continuing the reinforcing steel through the construction joints. Special measures are required when the continuity of the CRCP is terminated or interrupted with fixed structures or other pavements. The procedures provided in this chapter for the design of CRCP have been developed from observed performances of Corps flood control channels and the research of the design criteria used for continuously reinforced highway paving.

3-2. Constructibility of Paving Slabs on Sloped Sides of Channels

The characteristics of the in situ materials and the level of the water table are considered in determining the slopes of

channel sides. Small trapezoidal channels with depths of 3 m (10 ft) or less may be constructed with side slopes of 1 vertical on 1.5 horizontal. Slopes between 1 vertical on 3 horizontal and 1 vertical on 2 horizontal are commonly used for the sides of larger channels. Vibrating screeds are commonly used in constructing paving slabs on sloped sides within this range of steepness. Cylinder finishing machines are available for finishing paving slabs with slopes up to 1 vertical on 3 horizontal in steepness. Control units should be mounted at the top or bottom of sloped sides to provide the capability of finishing upgrade to eliminate slump in the finished slab. Machines are available for trimming and slipforming the entire cross section of channels with bottom widths up to about 3.5 m (12 ft) in one pass. Paving construction procedures should provide for the curing protection of completed paving.

3-3. Drainage Provisions

Drainage systems for channels formed in soil should be placed beneath paving slabs on bottoms of channels to relieve excessive hydrostatic pressures. The drainage system beneath the side slope paving typically does not need to extend higher than one-half the channel depth due to natural drawdown of the water table near the channel. The drainage system may need to extend higher than one-half of the slope height if the normal ground water is nearer the ground surface or a shallow perched ground water condition is encountered. Closed and open drainage systems have been used in past designs. Based on previous discussion in paragraph 2-4a, closed drainage systems should be used for large channels and where long-term performance of the drainage system is critical to channel life. Open drainage systems are sometimes sufficient for smaller channels and short channel sections, such as sections under bridges. The open drainage system can serve as an additional measure of protection for sections of channel where excessive hydrostatic pressures are not expected to develop. The design of channel paving slabs should reflect possible increased hydrostatic pressures resulting from some loss of drainage system effectiveness during the life of the project as discussed in paragraph 2-4e.

a. Open drainage systems. Open drainage systems consist of collector drains which drain through weep holes in the sloped sides of the paving. The collector drains should be encased with a graded filter material to prevent the blockage of drains or the removal of foundation materials. The weep holes are commonly spaced not more than 3 m (10 ft) apart horizontally.

b. Closed drainage systems. Closed drainage systems consist of drainage blankets, collector drains, collector manholes, and outlet drains as shown in Plate 1. Refer to Appendix C for a typical analysis of a drainage system for a paved trapezoidal channel.

(1) Drainage blankets. A drainage blanket must retain the foundation soils, allow relatively free movement of water, and have sufficient discharge capacity to convey all ground water seepage which enters the blanket to the collector pipes. Therefore, the drainage blanket must satisfy the requirements for both a drain and a filter. An open-graded granular material with a relatively narrow range in particle sizes has a higher permeability and discharge capacity than a well-graded granular material. However, a well-graded granular material is generally required to meet filter criteria. A two-layer drainage blanket will often be required to satisfy both the drainage and filter requirements. Estimated quantities of seepage which will enter the drainage blanket should be determined by seepage analyses. EM 1110-2-2502, EM 1110-2-1901, and Cedegren (1987) provide guidance on design of the drainage blanket. The blanket should have a minimum thickness of 150 mm (6 in.) for a single layer system, and each layer for a multilayer system should have a minimum thickness of 150 mm (6 in.).

(2) Collector drains. Collector drains should be 150-mm (6 in.) minimum diameter polyvinyl chloride pipe with perforations in the bottom half of the pipe's circumference. Drains should be located at the bottom of the sloped sides, inverts of channels, and at intermediate locations, if required, to prevent development of excessive hydrostatic heads in the drainage blanket. Drains should be placed on top of the drainage blankets and should be encased with a coarse filter gravel. The coarse filter gravel should be covered with a material such as kraft paper to prevent clogging during placement of the concrete paving. Guidance on sizing the drain pipe is presented in TM 5-820-2 and Cedegren (1987). Guidance on sizing the perforations is presented in EM 1110-2-2502, TM 5-818-5, and Cedegren (1987).

(3) Collector manholes. Collector manholes should be of precast or cast-in-place concrete and should be provided with secured, watertight manhole covers for clean-out access. Manholes should be provided with adapters or blind flanges for connecting outlet and collector drains. The size and spacing of manholes should be determined by a seepage analysis.

(4) Outlet drains. Outlet drains from collector manholes should be a minimum of 150 mm (6 in.) in

diameter. The outlet drains should be provided with check valves to prevent the backflow of water from channels into the drainage system. However, it may be more practical to attach the check valves to the collector drains on the inside of the manholes where channels are subjected to heavy sediment.

(5) Maintenance considerations. The design should provide for access to the drainage system to allow future maintenance and rehabilitation. Manholes should be sized and constructed to provide access to collector pipes for flushing, jetting, etc. Provisions should be made for cleanouts at locations where collector drains and laterals intersect, at intermediate points between widely spaced manholes, and at other locations as required to provide access to all segments of a drainage system for maintenance and rehabilitation.

c. Pressure relief systems. Pressure relief systems should be developed for areas where perched ground water is encountered during construction.

d. Monitoring. The most positive method of monitoring performance of the drainage system is to install piezometers in the drainage blanket to directly measure hydrostatic pressures acting against the channel paving. Piezometers are sometimes installed to monitor the effectiveness of the drainage system. When piezometers are not installed, the drainage system should be monitored for discharge during drawdown periods. The drainage system should be evaluated during the inspections discussed in paragraph 3-12a.

3-4. Continuously Reinforced Concrete Paving

a. Concrete.

(1) Concrete strength. Concrete should have a minimum compressive strength of 25 MPa (3,000 psi). Channel paving is not normally designed for heavy vehicular loading as highway paving; therefore, the compressive strength is specified instead of flexural strength. Control of the concrete strength is important to the design since shrinkage increases as concrete strengths are increased. Concrete with nominal compressive strengths higher than 25 MPa (3,000 psi) will require greater percentages of reinforcement than those given in Tables 3-1 and 3-2. Therefore, CECW-ED approval should be obtained when the nominal concrete strength for continuously reinforced concrete channel paving exceeds 3,000 psi.

(2) Concrete thickness. Based on past experience, the minimum thicknesses of main channel paving

Table 3-1
Minimum Percentage of Reinforcing Steel

For Continuously Reinforced Concrete Paving of
Invert and Side Slopes of Trapezoidal Channels

Longitudinal Reinforcing Steel

$f'_c < 25$ MPa 3,000 psi - reinforcement = 0.40%

$f'_c > 25$ MPa 3,000 psi - reinforcement percentage as
required by Equations D-1 and D-3 of Appendix D.

Transverse Reinforcing Steel

Widths < 12 m (40 ft) = 0.15%

Widths > 12 m (40 ft) - Same as longitudinal
reinforcement

* The total channel width should not be used, but instead, the
width of the slab sections which extends between changes in slope
or along the slope should be used.

Table 3-2
Longitudinal Reinforcing Steel

Design Reinforcing Steel Percentage Based on
Average Seasonal Temperature Differential

(Equation D-2 of Appendix D, using $f'_c \leq 25$ MPa 3,000 psi
 $f_t \leq 2$ MPa 230 psi and $f_y = 500$ MPa 60,000 psi)

Delta T, °C (°F)	67 (120)	78 (140)	89 (160)
Steel Percentage	0.43	0.48	0.53

supported on soil foundations should be 200 to 250 mm (8 to 10 in.) for invert paving and 150 to 200 mm (6 to 8 in.) for slope paving, respectively. Thicknesses of pilot channel paving should be 250 mm (10 in.) or greater when flows carry scouring materials. The bottom slab and side slope paving thickness may be decreased to 150 mm (6 in.) for small side channels with the bottom slab less than 4.5 m (15 ft) wide and channel depths less than 3 m (10 ft). Paving of rock is usually not required; however, when required, the paving thickness should not be less than 13 mm (5 in). The designer should verify that the pavement is adequately designed for equipment loads which may occur during construction, maintenance, and operation of the channel.

b. Reinforcement. Reinforcing steel should comply with paragraph 2-3a. Typically, a single layer of reinforcement should be used. The longitudinal steel should be located at or slightly above the center of the slab. The spacing of longitudinal bars should not exceed two times

the paving thickness, and the spacing of transverse bars should not exceed three times the paving thickness.

(1) Minimum cover. Reinforcement should be placed in such a manner that the steel will have a minimum cover of 75 mm (3 in.). The thickness of paving subjected to high-velocity flows or heavy sand scouring should be increased to provide a 100-mm (4-in.) cover on the reinforcement.

(2) Percentage of reinforcing steel. Reinforcing steel for CRCP slabs on soil foundations should comply with Table 3-1 or Table 3-2, whichever governs. The minimum percentage of reinforcing steel is given in Table 3-1, and the design percentage of longitudinal reinforcing based on the seasonal temperature differential is given in Table 3-2. Both longitudinal and transverse reinforcing steel in paving slabs on rock foundations should be in accordance with the longitudinal steel requirements of Table 3-1.

(3) Splices in reinforcement. Splices in reinforcement should conform to American Concrete Institute (ACI) Building Code Requirements for Reinforced Concrete 318 (ACI 1989). Splices should be designed to develop the full-yield strength of the bar. Fifty percent of the splices should be staggered, and the minimum stagger distance should be 1 m (3 ft).

(4) Bar size. Typically, bar sizes #10, #15, or #20 (#4, #5 or #6), are used for reinforcing CRCP. The bar size should be limited to a #6 to satisfy bond requirements and control crack widths. Reinforcing may be placed in two layers when a single layer would result in bar spacings that inhibit concrete placement.

c. Pavement subject to vehicular traffic. Channel pavement designed in accordance with paragraph 3-4a. and 3-4b is adequate for light vehicular traffic. Pavement that will be subjected to heavy vehicular traffic, such as loaded dump trucks, should also be designed in accordance with TM 5-809-12. The modulus of subgrade reaction k , used in designing for the wheel loads, is dependent on the drainage blanket material and the in situ foundation material below the pavement slab and these values should be selected by the geotechnical engineer.

3-5. Construction Joints

Construction joints should be placed in continuously reinforced paving to provide longitudinal joints between adjacent lanes of paving, where concrete pours are

terminated at the end of the day or when delays in concrete placement would otherwise result in the formation of cold joints. The length of time for cold joint development depends on the severity of temperature, humidity, and other factors. Contract specifications should specify the maximum delay time permitted prior to the requirement for formed construction joints. Concrete should be placed alternately in lanes of channel with multiple lanes. Small channels may be constructed without longitudinal joints. Reinforcing steel should be continuous through all construction joints. In addition, the amount of longitudinal reinforcement through transverse joints should be increased 50 percent to accommodate stresses as the pavement gains strength near the joint. This is accomplished by the addition of a 2-m (6-ft) long bar, of the same size as the longitudinal bars, placed between every other longitudinal bar.

3-6. Expansion Joints

Expansion joints should be provided in continuously reinforced paving at channel intersections and where paving abuts other structures such as box culverts, bridge piers, and bridge abutments. A 25-mm (1-in.) expansion joint is acceptable for concrete linings on soft ground when end anchorage is provided. When end anchorage is not provided, a 75-mm (3-in.) expansion joint should be provided for continuous paving on soft ground. Expansion joints in paving on rock will probably not function because of the interlock and bond between the concrete and paving. However, a 12-mm (1/2-in.) expansion joint should be provided in paving on rock where thinner paving sections abut thicker sections or structures. Expansion joints should be provided with a waterstop, smooth dowels, sponge rubber filler, and sealant. Expansion joint details for continuous concrete paving are shown in Plate 1.

3-7. End Anchorage

There is not sufficient friction between the concrete pavement and the drainage blanket material or soft ground to prevent substantial movements at the ends of continuously reinforced concrete pavements due to temperature effects. End anchorage is typically used to minimize movement and damage at the ends of paving or where the continuity of paving is interrupted by other structures. An acceptable anchorage system consists of three structurally reinforced concrete anchorage lugs which are keyed into the foundation material. The lugs are usually 40 mm (1.5 in.) thick by 1 m (3 ft) deep, cast with dowels for anchoring the paving and spaced transversely at 3-m (10-ft) centers, beginning about 1.5 m (5 ft) from the end of paving. Lug depth may vary depending on soil and frost conditions.

Anchor lugs should not be used in soils having poor resistance characteristics. Two layers of reinforcement should be provided in the pavement in the area of the lugs to develop the lug bending. Typical end anchorage details are shown in Plate 1.

3-8. Cutoff Walls

a. Scour protection at ends of concrete paving. Cutoff walls should be provided at the ends of the main channel and side channel paving to prevent undermining or the transporting of foundation materials from beneath the paving. Reinforced concrete cutoff walls should be provided when their use is suited to the foundation materials. Sheetpile cutoff walls should be provided in pervious materials. Cutoff walls should be keyed into undisturbed foundation materials and should extend up the side slopes to the standard project flood elevation. The unpaved reaches of the channels immediately upstream of cutoff walls in side channels, immediately downstream of cutoff walls in side channels, and immediately downstream of cutoff walls in main channels should be protected by riprap as required.

b. Cutoffs at top edges of paving. Cutoffs should be provided along the top edges of the channel paving. The depth of approximately 0.5 m (1.5 ft) is usually sufficient to prevent water from entering beneath the slab foundation due to minor amounts of scour or ground settlements. A typical detail of the cutoff at the top edge of paving is shown in Plate 1.

3-9. Intersecting Channels

a. Configuration. The design configuration of channel intersections should be coordinated with hydraulic engineers. Channel intersections and interruptions such as access ramps should have smooth curves, tangent to the main channel when possible to minimize the interruption of smooth channel flow. Abrupt changes in the normal channel cross section can cause standing waves which overtop the paving or impinge on bridges crossing the channel.

b. Intersection of side channel and main channel paving. Paving damage occurs when long lengths of intersecting side channel paving are made monolithic with the main channel paving. This damage occurs because of the "jacking" action during high temperatures. Therefore, an expansion joint should be placed in the intersecting side channel paving no more than 15 m (50 ft) from the intersection. When the intersecting side channel paving is more than 45 m (150 ft) long, the side channel

subdrainage system should not connect with the main channel subdrainage system.

c. Drop structures. Where the invert of the main channel is below the invert of the intersecting side channel, a drop structure may be necessary. A concrete or sheetpiling cutoff wall should be provided at drop structures to block transmission of pressure from the higher to the lower channel paving.

d. Partially paved main channel. When channel side paving does not extend up to the standard project design flood elevation, provisions should be made at channel intersections to prevent undermining and scour which could cause failure and to prevent the occurrence of inflows which would increase the hydrostatic pressures beneath the paving. Channel side paving should be extended up to the standard project flood elevation or top of bank, whichever is less, for a distance of 15 to 30 m (50 to 100 ft) upstream and downstream of intersections. Consideration should also be given to increasing the depth of the cutoff at the top edge of the sides.

3-10. Deficiencies in Past Designs of Paved Trapezoidal Channels

a. Jointed paving of partially lined channels. Significant changes in channel water levels, combined with the formation of water paths to and under paving, have permitted inflows greater than drainage systems were able to relieve. These heavy inflows resulted in excessive uplift pressures which have caused failures in jointed paving of partially lined channels. The excessive uplift pressures caused separations at the joints in the channel bottom paving and subsequent movement of the separated paving sections by flowing water. Paving on the sloped sides of channels usually failed after the failure of bottom paving. Paragraph 3-9*b* discusses solutions to alleviate this deficiency.

b. Intersecting channels. Excessive expansion or elongation of paving due to high seasonal temperatures has caused “jacking” in paving at channel intersections. “Jacking” action causes the paving to lift off the supporting foundation and places its underside in compression. This compressive force causes localized cracking, pop-outs, and spalling. Expansion joints, similar to the details shown in Plate 2, should be provided at intersecting channel pavements to prevent damage. Reference is also made to paragraph 3-9*b*.

c. Penetrations. In past designs stress concentrations have caused failures in continuous paving when the

continuously reinforced paving was interrupted by large penetrations for drainage culverts or pipes. Reinforced concrete frames, structurally integral with the continuous paving, should be provided as a stiffening system around penetrations or openings greater than 0.6 m (2 ft) to prevent failure of the channel paving. Thrust stiffening members should be provided in the longitudinal direction with thickened members at each end to collect and distribute the loads into the paving slab. A typical detail of the stiffening system is shown on Plate 2. When the channel paving is penetrated by structures with an outside dimension greater than 1.2 m (4 ft) the paving should be separated from the drainage structure with expansion joints which extend completely across the channel paving. A typical detail for treatment at large penetrations is shown in Plate 2.

3-11. Drainage Layer Construction

Major considerations during drain placement include:

- a.* Prevention of contamination by surface runoff, construction traffic, etc.
- b.* Prevention of segregation.
- c.* Proper compaction.
- d.* Proper layer thickness
- e.* Monitoring of gradations.

EM 1110-2-1901, EM 1110-2-1911, and EM 1110-2-2300 provide guidance for the construction of drainage layers.

3-12. Maintenance Considerations

A drainage system will be most effective when initially constructed and will deteriorate thereafter. Even with design precautions, deterioration of the system will occur. The system cannot be designed to prevent contamination throughout the life of a project without proper maintenance. Contamination of the drainage system can occur as a result of malfunctioning check valves, migration of foundation soils into the drainage blanket, growth of algae or bacteria, etc. Therefore, regular and routine maintenance is necessary for a drainage system.

a. Inspection and maintenance. The frequency of project inspections is discussed in paragraph 2-7. The inspection should check for proper operation of check valves, sediment in manholes, obvious differential movements between joints, leakage through joints, discharge of

sands from collector pipes, etc. Routine maintenance should include removal of sediment from manholes and collector drains. Repair of check valves, etc., should be performed as deficiencies are noted, and all deficiencies critical to performance of the project should be corrected with urgency. Additional guidance for inspection and maintenance of drainage systems is presented in EM 1110-2-1901.

b. Rehabilitation. The majority of rehabilitation of drainage systems is in connection with contamination of the collector pipes and drainage blankets by the backflow of silt-laden channel water. Rehabilitation can also be required because of incrustation, growth of algae or bacteria, migration of fines in foundation soils into the drainage blanket, etc. Pumping, jetting, flushing, and treatment with certain chemicals or detergents can be used in rehabilitation. Guidance for the rehabilitation of drainage systems is presented in EM 1110-2-1901.

3-13. Repair of Damaged Paving

Several concrete paving failures have occurred in the past which required the removal and replacement of the failed

sections. In some cases, the repairs were made without evaluating the cause of damage which allowed future failures to occur. Therefore, when repair measures are necessary the cause of the failure should be determined and all provisions should be taken to prevent any recurrence of the damage. When such repairs are made the reinforcing steel along the edge of removed paving section should be preserved and lapped with the new reinforcement in the repair section. The area of the longitudinal reinforcing steel in small repaired areas is often doubled. This is done because the edges of the existing channel paving around the break-out move due to temperature changes, and the concrete in the repaired area shrinks during curing. High-early strength concrete is sometimes used to shorten the curing time of the repair concrete. For repairs requiring long periods of construction, sheetpile cutoffs should be installed beneath the existing paving at upstream and downstream limits of repaired area. These cutoffs are provided to prevent further damage to the paving should flood flows occur which are larger than those which can be controlled by the construction cofferdam and the bypass system.

Chapter 4

Special Design Considerations for Rectangular Channels Lined with Retaining Wall Structures

4-1. General

The stems of retaining walls used to line rectangular channels are vertical or nearly vertical. These walls must retain the surrounding soil and contain the channel flows. Although rectangular channels are more expensive than trapezoidal channels, they are sometimes justified in highly developed urban areas. Limitations on economical right-of-way may not allow for construction of excavations with stable slopes. In such cases, rectangular channels are required.

4-2. Retaining Wall Types

Cantilever and I-type reinforced concrete retaining walls are commonly used to form the sides of rectangular channels. These walls are used with or without bottom channel paving as shown in Figure 2-2.

a. Cantilever walls. Cantilever walls are usually the inverted T-type or L-type. The inverted T-type wall develops additional stability because of the weight of the backfill material resting on the heel of the base slab. The base slab of the L-type wall does not have a heel. Hence, stabilization is provided only by the weight of the wall itself. The L-type wall requires less excavation for construction.

b. I-type walls. I-type walls are often used when right-of-way restrictions prohibit sloped excavations as discussed in paragraph 2-8. I-type walls often consist of driven piles or concrete drilled piers with attached concrete face wall. Concrete slurry walls are also an alternative. The walls should be designed to prevent movements which would result in settlements or loss of materials which would be detrimental to existing structures or essential environmental features.

4-3. Channel Bottoms

Paving of channel bottoms is often required to prevent erosion of the in situ materials when subjected to channel flows or to satisfy other environmental factors. Joints in channel bottom paving slabs should be avoided, when possible, by the use of continuously reinforced concrete

paving. Guidance for continuously reinforced concrete paving is contained in paragraphs 3-4, 3-6, 3-7 and 3-8a.

4-4. Joints In Retaining Walls

Vertical contraction joints should be placed in the wall stem at a spacing of approximately 5 to 10 m (20 to 30 ft). Wall base slabs may be designed as continuously reinforced slabs. Horizontal construction joints should be provided at the base of wall stems and at vertical lifts of 2.5 to 3 m (8 to 10 ft) in walls. Guidance for joints in retaining walls is contained in EM 1110-2-2502.

4-5. Drainage Provisions

a. Drainage systems. Except for I-type walls, drainage systems should be provided behind channel retaining walls and beneath channel bottom paving slabs on soil foundations to relieve hydrostatic pressures whenever the permanent or fluctuating water table is above the invert of the channel. General information on the design of drainage systems is provided in paragraph 2-4. Since construction procedures do not permit the installation of a drainage system behind I-type walls, these walls should be designed for the unrelieved hydrostatic pressures which may occur throughout the life of the walls.

(1) Retaining walls. EM 1110-2-2502 provides information for the design of drainage systems to relieve hydrostatic pressures on retaining walls. Details of the drainage systems for rectangular channels, including those formed with retaining walls, are shown in Plate 2. Backfill material placed behind channel retaining walls should be a pervious, free draining, granular material to ensure the lowest level of saturation and to minimize horizontal earth pressures. The pervious backfill material should be covered with a layer of impervious material to prevent surface runoff from entering the backfill.

(2) Channel bottom paving slabs. When channel bottom paving slabs are placed on rock foundations, the drainage system usually consists of a system of holes drilled in the rock and weep holes in the slab. The depth of holes required to achieve the required drainage effectiveness is dependent on the type and condition of the rock. The geotechnical engineer should be consulted in this regard. If paving anchors are provided, the depth of drain holes should not be less than the depth of the anchors. When drainage is required for channel bottom paving slabs on soil foundations, a drainage system as discussed in paragraph 3-3 should be used.

(3) Hydrostatic pressures. The intensity of the hydrostatic horizontal and uplift pressures on the structure is dependent upon the effectiveness of drainage system. The drainage system effectiveness is discussed in paragraph 2-4e. In past designs, it has been common to assume a 25 to 50 percent decrease in drain effectiveness. The design pressures must be based on these considerations. The design memoranda must provide adequate documentation to clearly show that the values used in the design are proper and result in an adequately conservative design. Appendix C provides methods for the design of the drainage system by the use of seepage analyses.

b. Pressure relief systems. Pressure relief systems should be provided for those areas where perched water is encountered during construction.

4-6. Structural Design

a. Loading conditions. The forces acting on rectangular channels should be defined to determine the design loadings as discussed in paragraph 2-3b. The following loading conditions are representative of the controlling conditions in which the design loadings are applied to cantilever and I-type retaining walls and the channel bottom paving slabs of rectangular flood control channels. Earth pressures on walls should be determined by using applicable criteria in EM 1110-2-2502, EM 1110-2-2504, and ETL 1110-2-322.

(1) Case 1, Construction loading (unusual condition). Wall and backfill in place; earth pressure; channel empty; compaction effects and construction surcharge loadings. See Figure 4-1a.

(2) Case 2, Design flood loading (usual condition). Wall and backfill in place; earth pressure; water level on the channel side at the design water level, plus freeboard; backfill saturated to normal-low ground water level, adjusted to reflect the design effectiveness of the drainage system. See Figure 4-1b.

(3) Case 3, Drawdown loading (usual condition). Wall and backfill in place; earth pressure; channel empty; backfill saturated to highest ground water level, adjusted to reflect the design effectiveness of the drainage system. See Figure 4-1c.

(4) Case 4, Earthquake loading (unusual condition). Wall and backfill in place; active earth pressure; water in channel to normal water level; backfill saturated to normal

ground water level, adjusted to reflect the effectiveness of the drainage system; earthquake induced loads. See Figure 4-1d.

b. Stability.

(1) Cantilever retaining walls. Stability analyses should be performed to determine the horizontal, vertical, and rotational equilibrium of these walls to ensure safety against sliding along the base or any foundation medium below the base, overturning, bearing, or excessive differential settlement of the foundation and flotation. The criteria for performing stability analyses of T-type and L-type retaining walls, including the factors of safety for sliding and overturning, are contained in EM 1110-2-2502. The flotation factors of safety and the criteria for performing the flotation analysis are given in ETL 1110-2-307. Computer program X0153, CTWALL, may be used for the analysis of these walls.

(2) I-type retaining walls. Stability analyses for I-type walls should be performed using a model which depicts the loaded wall embedded in the foundation material. Stability is achieved by the resistive foundation pressures on the embedded portion of the wall. A pictorial description of the I-wall is shown in Figure 2-2c. Computer program X0031, CWALSHT, may be used for the analysis of these walls.

(3) Channel bottom paving. Flotation stability of the channel bottom paving shall comply with criteria in ETL 1110-2-307. Pavement on rock may be anchored to resist flotation with reinforcing bars grouted into holes drilled into the rock.

c. Reinforced concrete design. Criteria for design of reinforced concrete hydraulic structures are given in EM 1110-2-2104. For singly reinforced flexural members, the ratio of tension reinforcement provided should be $0.375p_b$.

(1) Cantilever retaining walls. T-type and L-type walls should be designed for the loading cases described in paragraph 4-6a, as applicable, and the foundation pressures obtained from the stability analyses.

(2) I-type retaining walls. I-type walls should be designed for the loading cases described in paragraph 4-6a and the resisting forces which develop on the embedded portion of the wall.

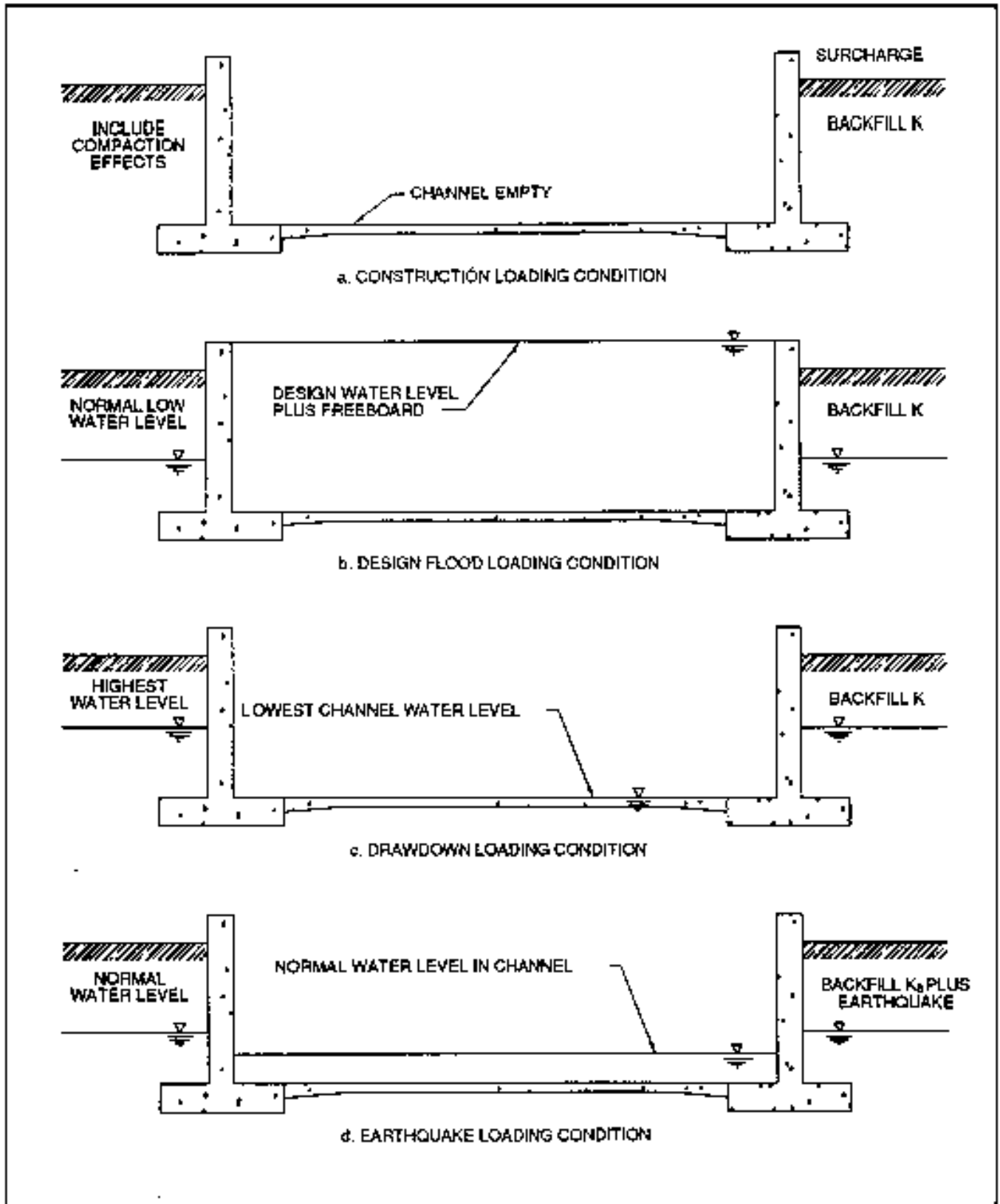

Figure 4-1. Loading conditions, rectangular channels with retaining walls

(3) Channel bottom paving.

(a) Minimum reinforcing. The minimum percentage of reinforcing steel should comply with Table 3-1 or Table 3-2, whichever is greater.

(b) Uplift loading. Channel invert paving should be designed for the maximum net uplift load. Pavement on rock which is anchored to resist flotation should be designed to span between the anchorage points. Anchors should be designed to provide a safety factor of 1.5 against the design uplift pressures.

(c) Isolated or buttress action. Paving slabs used in conjunction with retaining walls may be designed and

detailed to act independently or as a strut slab to provide horizontal support to the wall.

4-7. Special Considerations During Construction

When retaining walls are designed for the paving slab to act as a strut to provide sliding stability, contract requirements should stipulate that the slab should be placed prior to the construction of walls. Contract specifications should define any restrictions on the backfill differentials required to comply with the design assumptions.

Chapter 5 Special Design Considerations for Rectangular Channels Lined with U-frame Structures

5-1. General

The U-frame structure is basically a U-shaped, open-top concrete section in which the walls and base slab of the structure are monolithic. U-frame structures may sometimes be more economical or functionally desirable than individual retaining walls and separate channel invert slabs.

5-2. Foundation Considerations

U-frame channel structures may be designed for any type of foundation, provided the material strength is sufficient to provide adequate frictional and bearing resistance for structural stability. Pile foundations are sometimes used for localized sections founded on weak foundations.

5-3. Joints in Concrete

a. Base slab section. The base slab of U-frame channel structures are often designed and constructed as continuously reinforced concrete paving. Expansion joints should be provided where the continuity of the structure is interrupted by other structures. Guidance on expansion joints is discussed in paragraph 3-6. Waterstops should be provided in expansion joints and should extend continuously across the base slab. When continuously reinforced concrete paving is not used, vertical contraction joints are provided at the location of wall joints.

b. Wall section. Vertical contraction joints should be provided in walls of U-frame structures. The contraction joint spacing should be approximately 5 to 10 m (20 to 30 ft). However, the joint spacing should be limited to two or three times the wall height. Horizontal construction joints or vertical lift joints should be provided at the base of wall stems and in wall height at intervals of 2.5 to 3 m (8 to 10 ft).

5-4. Drainage Provisions

A drainage system should be provided behind the channel walls and beneath the channel bottom paving to relieve hydrostatic pressures whenever the permanent or fluctuating water table is above the invert of the channel. The design of channel walls and bottom paving should reflect

possible increased hydrostatic pressures resulting from some loss of the drainage system effectiveness during the life of the project as discussed in paragraph 2-4e.

a. Drainage systems. Open and closed drainage systems are discussed in paragraphs 2-4, 3-3, and 4-5. Refer to Appendix B for a typical analysis of a drainage system for a U-frame structure.

b. Drainage of perched ground water. When ground water levels are below the channel invert and a drainage system is not provided, the designer should develop a pressure relief system for those areas where perched water is encountered during construction of the channel. This drainage system should be defined and included as a requirement of the construction contract.

5-5. Structural Design

a. Loading conditions. The primary loadings on the U-frame structure are weights of the structure and contained water and the geohydraulic pressures resulting from the restraint provided by the structure. The exact nature of the loadings or the physical parameters on which the loadings are based are not precisely known; therefore, the structure should be designed for conservative loadings. An analysis of the structural frame should be performed with the applied loading to determine the reactive foundation pressures and internal loads within the structure for each loading condition.

(1) Case 1, Construction condition (unusual condition). Structure complete with backfill in place; at-rest earth pressure; channel empty; compaction effects and construction surcharge loadings. See Figure 5-1a.

(2) Case 2, Design flood loading (usual condition). Water in channel at the maximum design water level; at-rest earth pressure; backfill saturated to the normal ground water level adjusted to reflect the design effectiveness of the drainage system. See Figure 5-1b.

(3) Case 3, Drawdown loading (usual condition). Channel empty; at-rest soil pressures on walls; hydrostatic pressures reflecting the highest ground water level adjusted to reflect the design effectiveness of the drainage system. See Figure 5-1c.

(4) Case 4, Earthquake loading (unusual condition). Construction complete; water in channel to normal level; active earth pressures; backfill saturated to normal ground water level adjusted to reflect the design effectiveness of the drainage system; seismic loadings. See Figure 5-1d.

(5) Case 5, Other special load cases. Modify all of the previous load cases to include other special loads applied to the U-frame structure. Examples are maintenance vehicles and bridges or other permanent structures which are supported by the U-frame.

b. Stability. The basic stability requirements for the U-frame structure require that the structure be safe against sliding, overturning, bearing failure (excessive differential settlement), and flotation. The criteria for satisfying these stability requirements and the safety factors required for usual and unusual loading conditions are contained in EM 1110-2-2502, Chapter 4, particularly Table 4-1. Resisting loads or foundation pressures on the base of structure are computed to satisfy vertical and rotational equilibrium. The distribution and intensity of base pressures should be determined by using a beam on elastic foundation model, or by use of a pressure pattern which approximates that which would exist beneath a flexible foundation. Excessive differential settlements are avoided by maintaining bearing pressures which are less than the allowable bearing pressure value furnished by the geotechnical engineer. Flotation stability criteria for concrete hydraulic structures is contained in ETL 1110-2-307. Anchors are sometimes necessary to satisfy the safety factor requirements. In rock foundations, anchors often consist of reinforcing bars grouted into drilled holes. The stiffness, strengths, and locations of anchors should be reflected in the structural analysis.

c. Reinforced concrete design.

(1) General. Reinforced concrete design should comply with EM 1110-2-2104. For singularly reinforced flexural members the ratio of tension reinforcement provided should be $0.375p_b$.

(2) Minimum reinforcement. Reinforcement for continuously reinforced concrete slabs on soil foundations should comply with Tables 3-1 or 3-2.; except that the area of temperature reinforcement in thicker slabs need not exceed $2,200 \text{ mm}^2$ per meter (1 in.^2 per foot). Reinforcement should be placed in two layers, top and bottom of slab, when the slab thickness is 300 mm (12 in.), or greater. For thicker slabs it is common to place $2/3$ of the reinforcement in the top face. Minimum temperature and shrinkage reinforcement provisions are discussed in EM 1110-2-2104.

d. Computer programs. Computer programs suitable for the design or analysis of U-frame structures are discussed in Appendix B.

5-6. Special Considerations During Construction

Construction procedures should be given consideration during the design process. Construction difficulties and complexities should be minimized or eliminated. For example, concrete working slabs are sometimes used to protect drainage blankets or to prevent weathering of the foundation materials before the main slab is constructed. When necessary for stability, the contract should include the requirement for the level of backfill behind opposite walls to be limited to a specified differential.

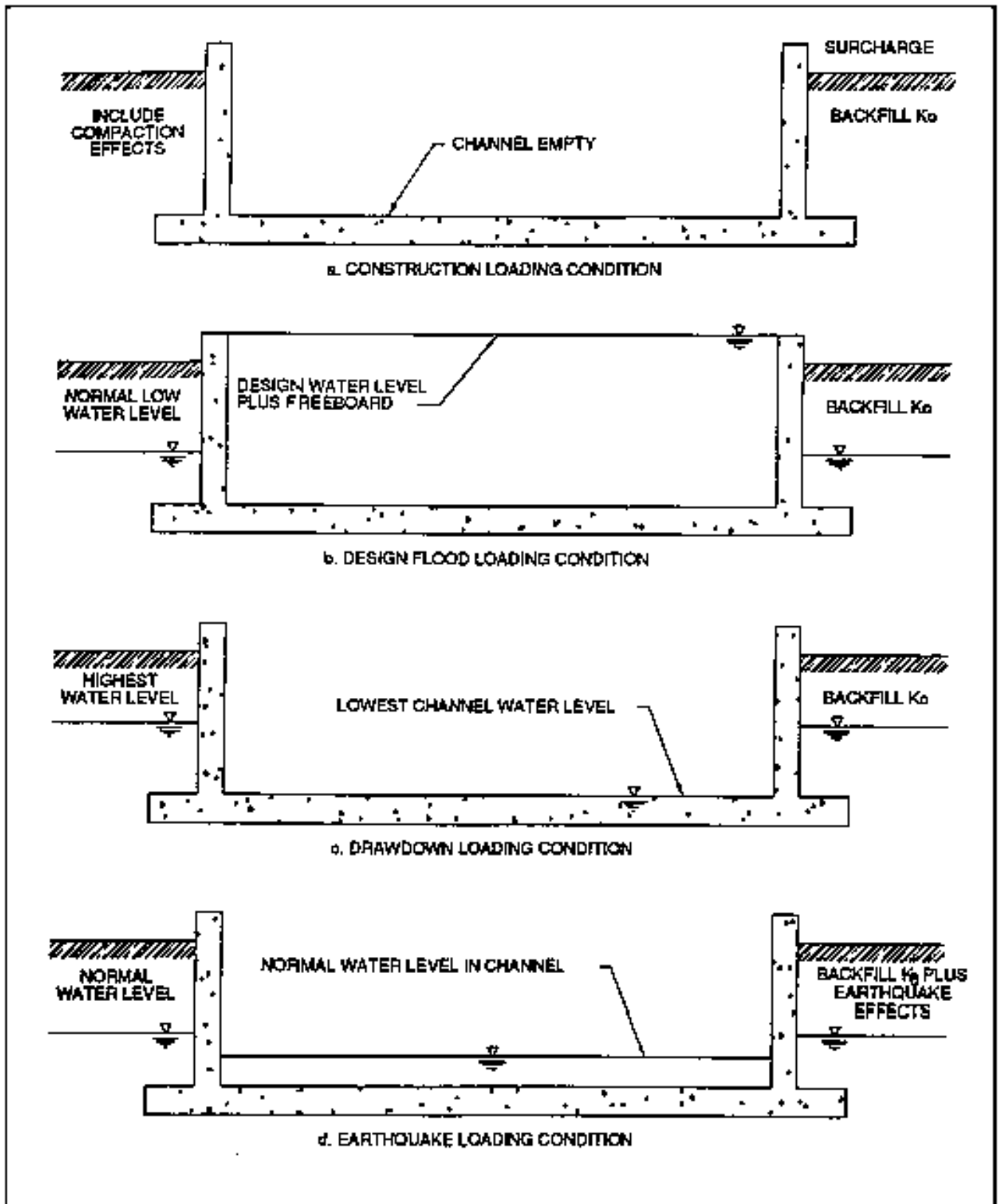
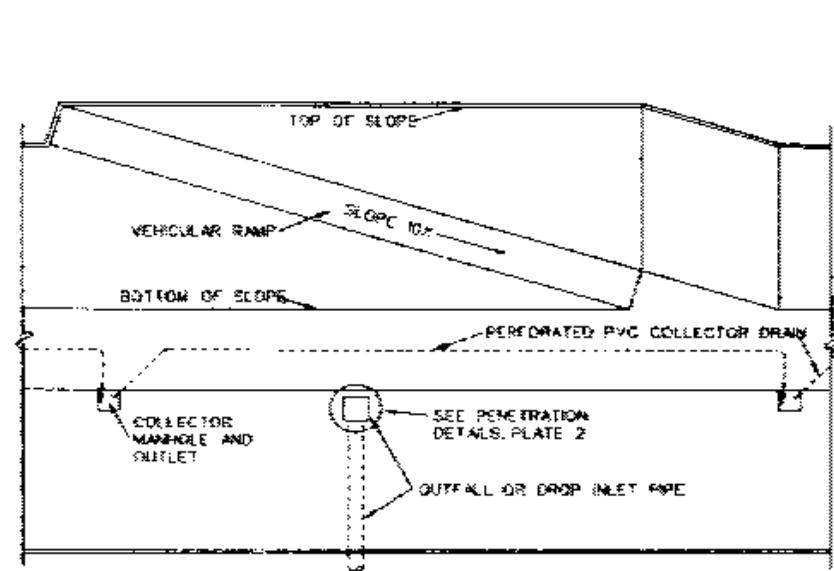
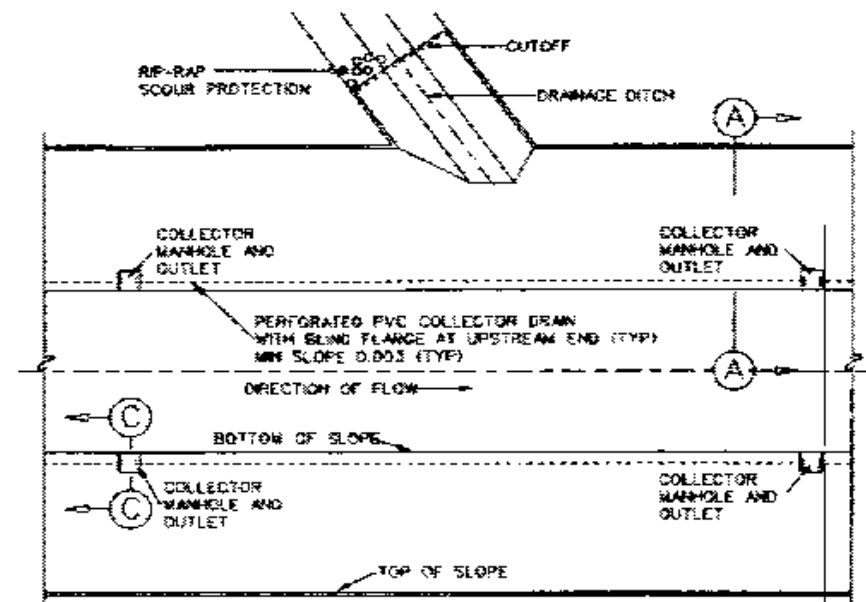

Figure 5-1. Loading conditions - rectangular channels with U-frames



CHANNEL WITH ONE DRAIN LINE
NO SCALE



CHANNEL WITH TWO DRAIN LINES
NO SCALE

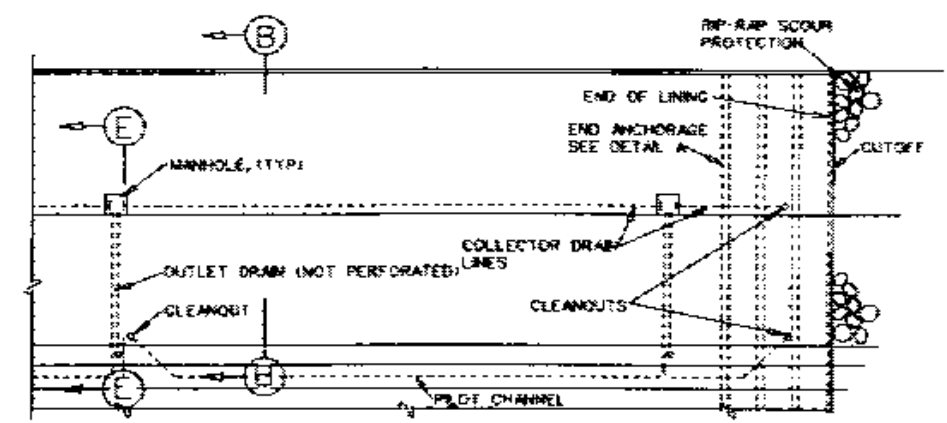

CHANNEL WITH PILOT CHANNEL
NO SCALE

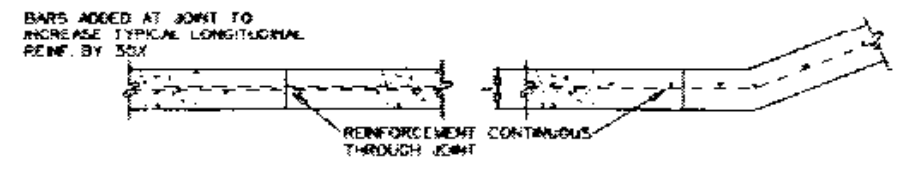

TRANSVERSE CONSTRUCTION JOINT
LONGITUDINAL

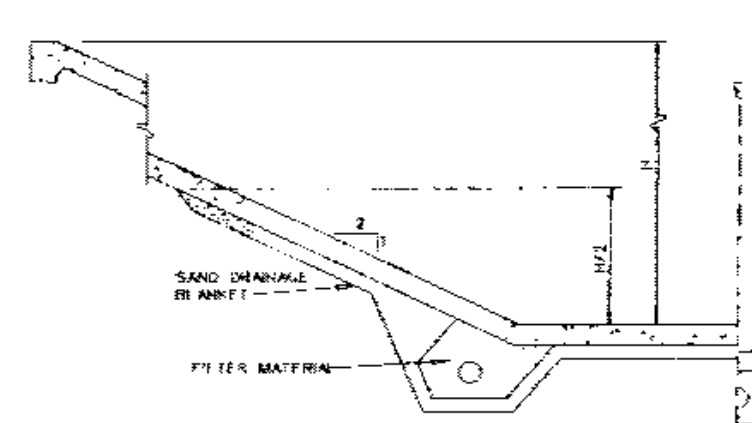

SECTION A-A

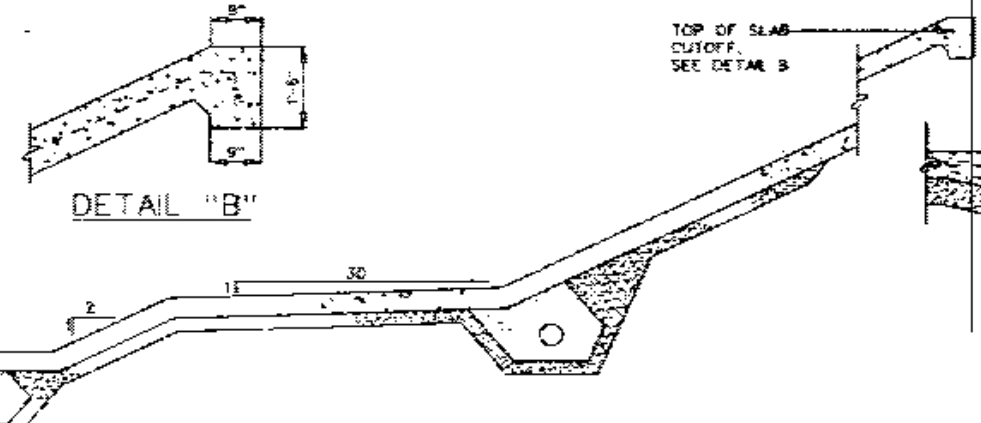

SECTION B-B

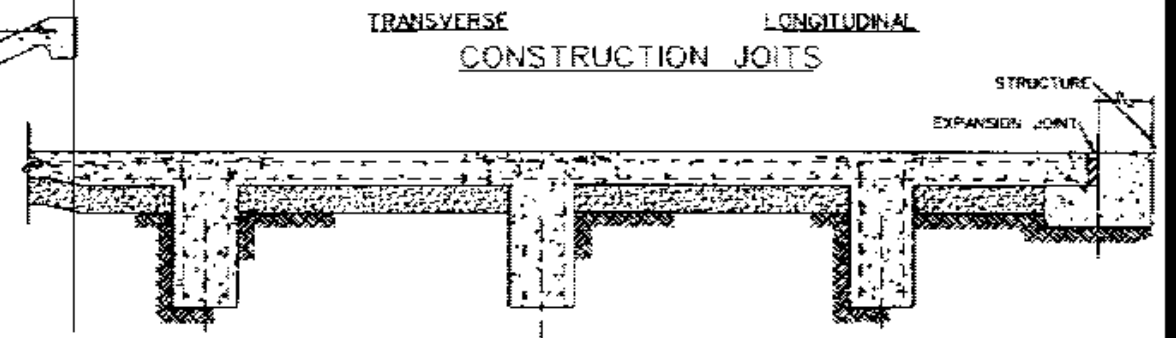

DETAIL A
NO SCALE

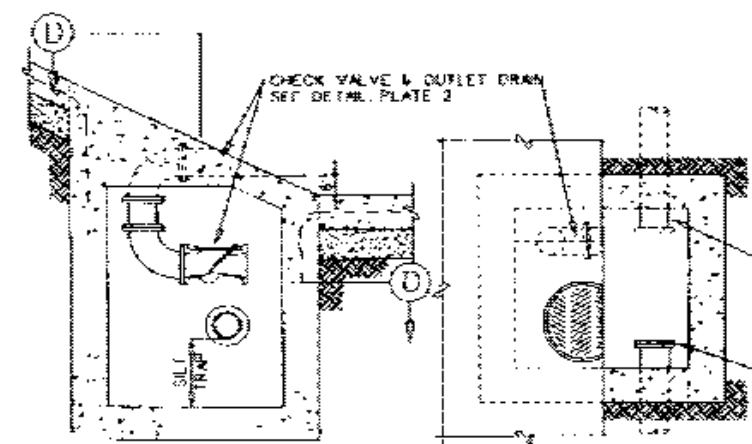

SECTION C-C

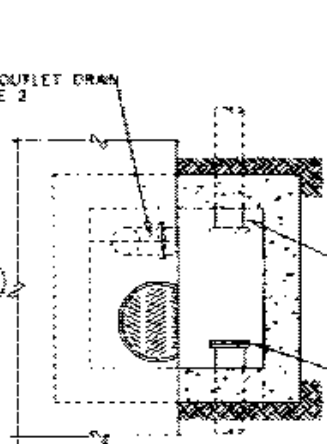

SECTION D-D

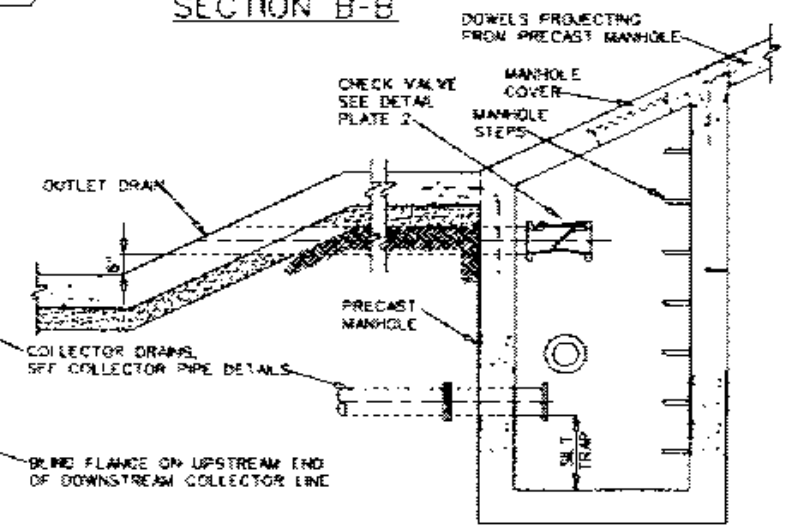

SECTION E-E

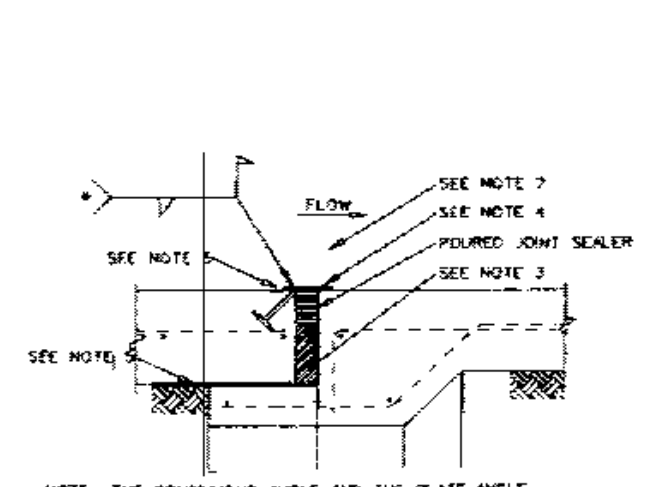

NOTE: THE CONTINUOUS ANGLE AND THE PLATE-ANGLE WELD SHALL BE LOCATED AT THE UPSTREAM SLAB.

SLAB EXPANSION JOINT DETAIL
NO SCALE

- NOTES
1. FOR OUTLET AND INLET DETAIL SEE PLATE 2
 2. FOR DETAILS OF PENETRATIONS IN CONCRETE LINED TRAPEZOIDAL CHANNELS, SEE PLATE 2.
 3. POLYETHYLENE FOAM FILLER, "PLASTAZONE" OR APPROVED EQUAL. DO NOT ANCHOR WITH NAILS OR BONDING AGENT. KEEP IN PLACE WITH FRESH CONCRETE. DO NOT ALLOW FRESH CONCRETE BETWEEN FILLER AND PREVIOUSLY PLACED CONCRETE.
 4. CONTINUOUS GALVANIZED PLATE
 5. CONTINUOUS GALVANIZED ANGLE WITH HEADED STUDS.
 6. LOW DENSITY POLYETHYLENE BEARING PLATE ATTACHED TO LOWER SLAB WITH ADHESIVE. COMPACT SOE TO TOP PLANE OF PLATE.
 7. SEE FIGURE 3-6 OF TM 5-825-3 FOR DETAIL OF EXPANSION JOINTS
 8. SEE PLATE 2 FOR COLLECTOR PIPE DETAILS

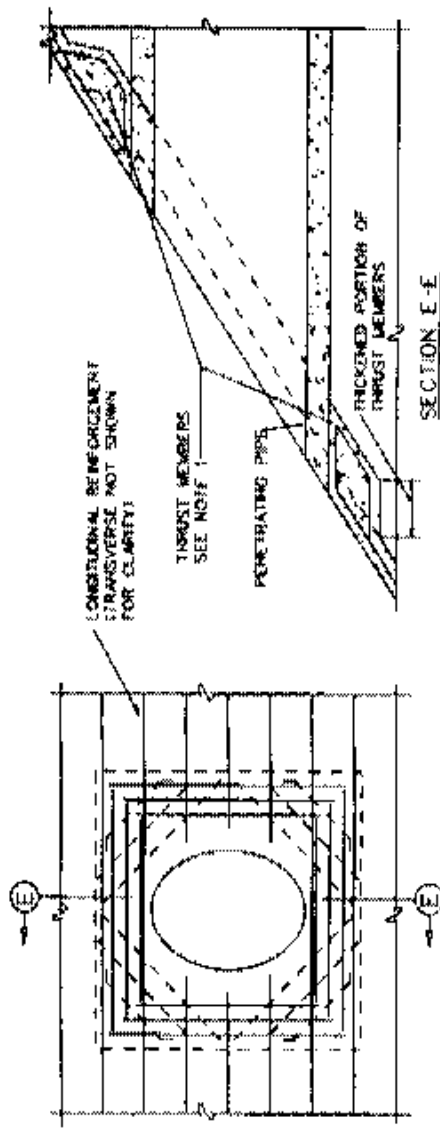

SECTION E-E
NO SCALE
0.6 TO 1.2m (2 TO 4 ft) PENETRATIONS

BY SLAB EXPANSION JOINT
SEE DETAIL PLATE 1
ALSO SEE NOTE 3

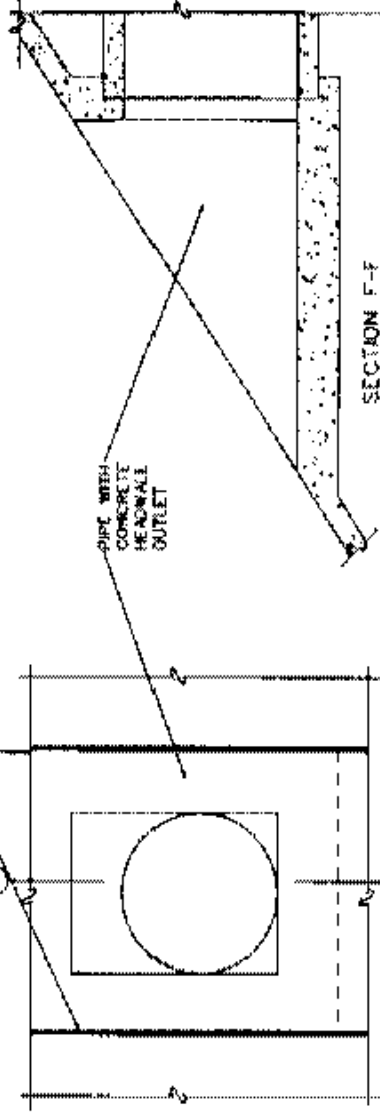

SECTION F-F
NO SCALE
PENETRATIONS > 1.2m (4 ft)

PENETRATION DETAILS
CONCRETE LINED TRAPEZOIDAL CHANNELS

NOTES:

1. THE AREA OF CONCRETE AND REINFORCEMENT IN THE THICKENED PORTION OF THRUST MEMBERS SHOULD BE 2 TO 3 TIMES THE AREA ENCOUNTERED BY THE PENETRATING PIPE.
2. LOW DENSITY POLYETHYLENE PLATE.
3. EXPANSION JOINTS EXTEND ACROSS FULL WIDTH OF CHANNEL PAVING.

EM 1110-2-2007
FLOOD CONTROL CHANNELS
CONCRETE LINES
RECTANGULAR CHANNELS
TYPICAL DETAILS
DEPARTMENT OF THE ARMY U.S. ARMY CORPS OF ENGINEERS WASHINGTON, D.C.

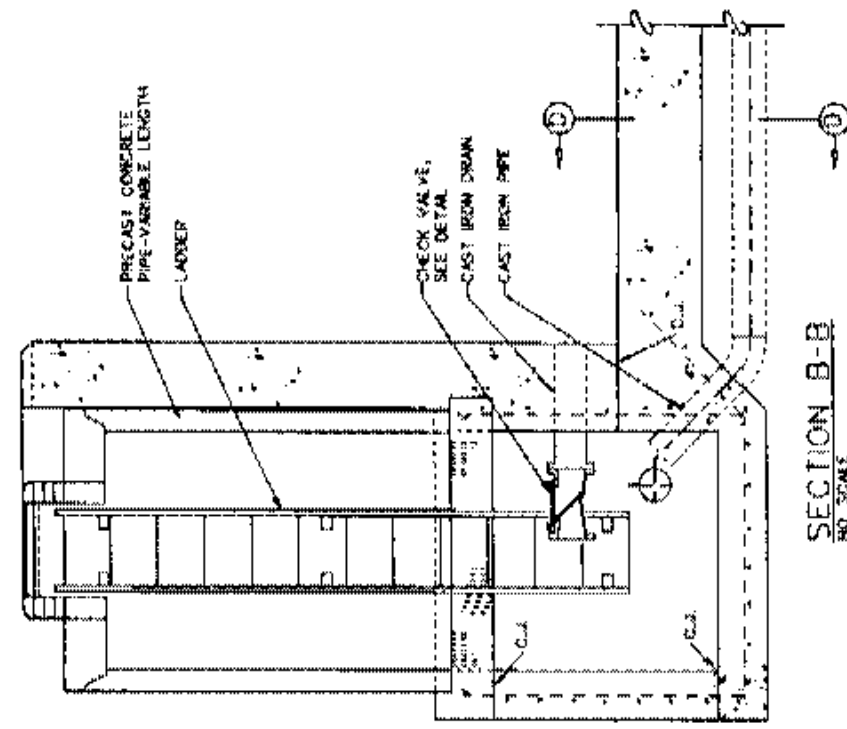

SECTION B-B
NO SCALE

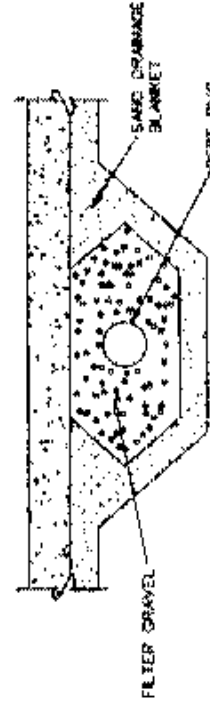

SECTION D-D
NO SCALE

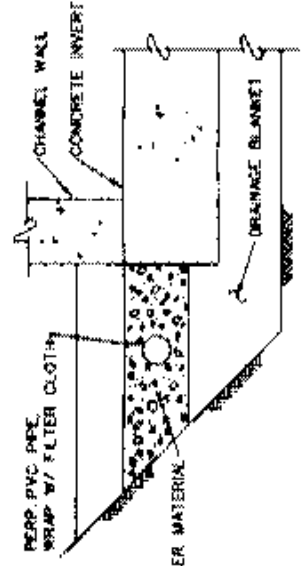

SECTION C-C
NO SCALE

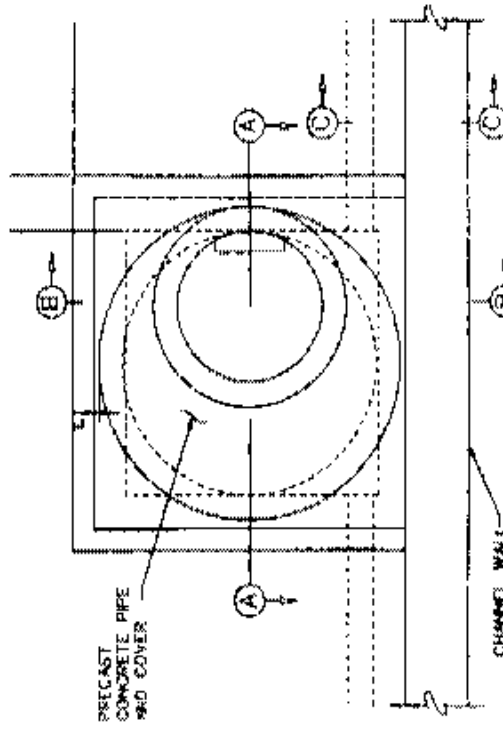

PLAN MANHOLE
NO SCALE

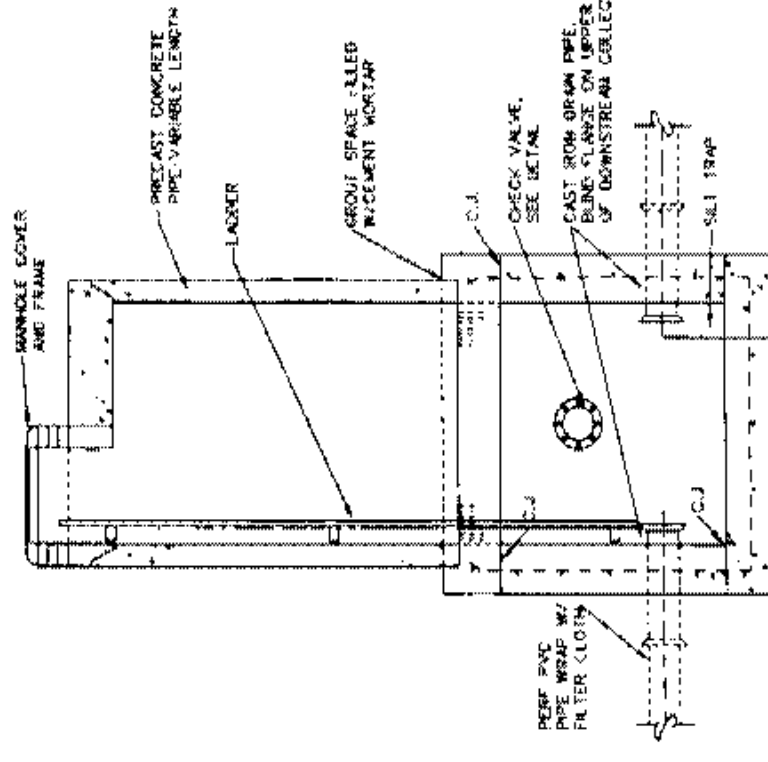

SECTION A-A
NO SCALE

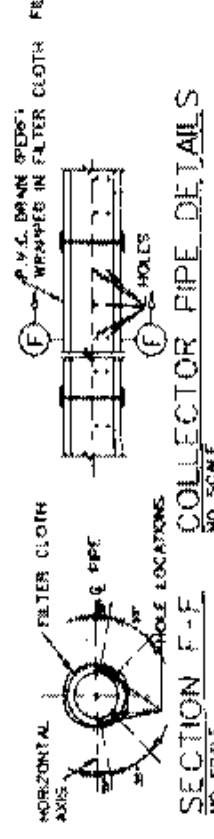

SECTION F-F
NO SCALE
COLLECTOR PIPE DETAILS

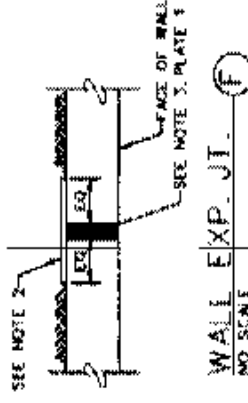

WALL EXP. JT.
NO SCALE

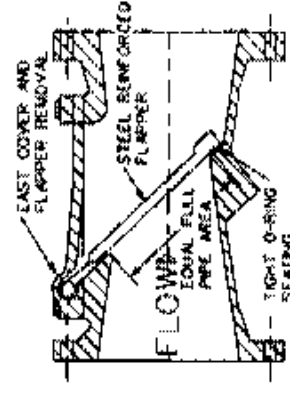

DETAIL
NO SCALE
RUBBER FLAPPER SPRING CHECK VALVE MODEL SHALL BE BY ARCO VALVE AND PRESS. CORP. SCHENECTADY, N.Y.

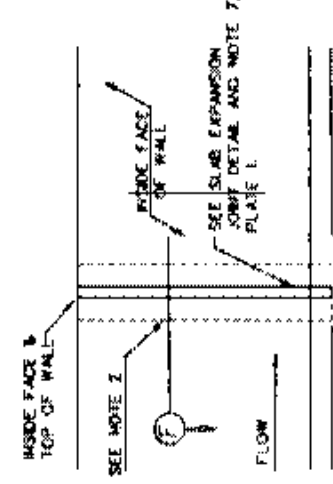

WALL ELEVATION
NO SCALE

OUTLET & INLET VALVE DETAIL
NO SCALE

Appendix A References

A-1. Required Publications

TM 5-809-12

Concrete Floor Slabs on Grade Subjected to Heavy Loads

TM 5-818-5

Dewatering and Groundwater Control

TM 5-820-2

Drainage and Erosion Control, Subsurface Drainage Facilities for Airfield Pavements

TM 5-825-3

Rigid Pavement for Airfields

ER 1110-2-1806

Earthquake Design and Analysis for Corps of Engineers Projects

EM 1110-1-1804

Geotechnical Investigations

EM 1110-2-38

Environmental Quality in Design of Civil Works Projects

EM 1110-2-301

Guidelines for Landscape Planting at Floodwalls, Levees, and Embankment Dams

EM 1110-2-1601

Hydraulic Design of Flood Control Channels

EM 1110-2-1901

Seepage Analysis and Control for Dams

EM 1110-2-1907

Soil sampling

EM 1110-2-1908

Instrumentation of Earth-Rock-Fill Dams (Ground-water and Pore Pressure Observations)

EM 1110-2-1911

Construction Control for Earth and Rock-Fill Dams

EM 1110-2-2000

Standard Practice for Concrete for Civil Works Structures

EM 1110-2-2102

Waterstops and Other Joint Materials

EM 1110-2-2104

Strength Design for Reinforced-Concrete Hydraulic Structures

EM 1110-2-2300

Earth and Rock-Fill Dams General Design and Construction Considerations

EM 1110-2-2400

Structural Design of Spillways and Outlet Works

EM 1110-2-2502

Retaining and Flood Walls

EM 1110-2-2504

Design of Sheetpile Walls

ETL 1110-2-307

Flotation Stability Criteria for Concrete Hydraulic Structures

ETL 1110-2-322

Retaining and Flood Walls

American Concrete Institute 1989.

American Concrete Institute. 1989. "Building Code Requirements for Reinforced Concrete." ACI 318, Detroit, MI. Available from American Concrete Institute, P. O. Box 19150, Redford Station, Detroit, MI 48219.

Biedenharn and Tracy 1987

Biedenharn, D. G., and Tracy, F. T. 1987 (May). "Finite Element Method Package for Solving Steady-State Seepage Problems," Technical Report ITL-87-6, U.S. Army Engineer Waterways Experiment Station (USAEWES). Available from USAEWES, 3909 Halls Ferry Road, Vicksburg, MS 39180-6199.

Cedegren 1987

Cedegren, H. R. 1987. *Drainage of Highway and Airfield Pavements*. Original published by Wiley, New York (1974); Updated printing by Robert E. Krieger Publishing Company Inc., Melbourne, FL, 289 pp. Available from USAEWES, 3909 Halls Ferry Road, Vicksburg, MS 39180-6199.

EM 1110-2-2007
30 Apr 95

Cedegren 1989

Cedegren, H. R. 1989. *Seepage Drainage and Flow Nets*. Wiley, New York, 465 pp. Available from USAEWES, 3909 Halls Ferry Road, Vicksburg, MS 39180-6199.

Knowles 1992

Knowles, Virginia R. 1992 (Aug). "Application of the Finite Element Seepage Analysis Corps Program CSEEP (X8202)," Available from USAEWES, 3909 Halls Ferry Road, Vicksburg, MS 39180.

Tracy 1983

Tracy, F. T. 1983 (Sep). "User's Guide for a Plane and Axisymmetric Finite Element Program for Steady-State Seepage Problems," Instruction Report K-83-4, USAEWES. Available from USAEWES, 3909 Halls Ferry Road, Vicksburg, MS 39180-6199.

A-2. Related Publications

ER 1110-2-100

Periodic Inspection and Continuing Evaluation of Completed Civil Works Structures

ER 1110-2-1150

Engineering and Design for Civil Works Projects

ER 1130-2-339

Inspection of Local Flood Protection Projects (RCS DAEN-CWO-40)

EM 1110-2-2200

Gravity Dam Design

EM 1120-2-109

Federal Participation in Major Drainage Improvements

Bowles 1982

Bowles, J. E. 1982. *Foundation Analysis and Design*, 3rd ed., McGraw-Hill, New York.

Dawkins 1991

Dawkins, W. P. "User's Guide: Computer Program for Design and Analysis of Sheet-Pile Walls by Classical Methods (CWALSHT)," Instruction Report ITL-91-1, USAEWES. Available from: USAEWES, 3909 Halls Ferry Road, Vicksburg, MS 39180-6199.

Department of the Navy 1982

Department of the Navy. 1982 (May). "Foundations and Earth Structures," NAVFAC DM-7.2. Available from

Department of the Navy, Naval Facilities Engineering Command, 200 Stoval Street, Alexandria, VA 22332.

Hays 1990

Hays, C. O. 1990. "Investigation and Design of U-Frame Structures Using CUFRBC, Volume A - Program Criteria and Documentation," Technical Report ITL-90-3, USAEWES, Vicksburg, MS. Available from USAEWES, 3909 Halls Ferry Road, Vicksburg, MS 39180-6199.

Hays and Ford 1989

Hays, C. O., and Ford, C. 1989. "Investigation and Design of U-Frame Structures Using CUFRBC, Volume C- User's Guide for Channels," Technical Report, ITL-90-3, USAEWES. Available from USAEWES, 3909 Halls Ferry Road, Vicksburg, MS 39180-6199.

Hays and Wright 1989

Hays, C. O., and Wright T. 1989. "Investigation and Design of U-Frame Structures Using CUFRBC, Volume B- User's Guide for Basins," Technical Report, ITL-90-3, USAEWES. Available from USAEWES, 3909 Halls Ferry Road, Vicksburg, MS 39180-6199.

Johns 1973

Johns, H. 1973 (Jan). "Joint Sealing in Reclamation Canals," *Journal, American Concrete Institute*, pp 14-18. Available from ACI Publications, P.O. Box 19150, Redford Station, Detroit, MI 48219.

Lacy and Gould 1985

Lacy, H. S., and Gould, J. P. 1985 (Oct). "Settlement From Pile Driving in Sands." *Vibration Problems in Geotechnical Engineering*. Proceedings, Geotechnical Engineering Division, American Society of Civil Engineers. Available from American Society of Civil Engineers, 345 East 47th Street, New York, NY 10017-2398.

Pace and Noddin 1987

Pace, M. E., and Noddin, V. R. 1987 (Oct). "Sliding Stability of Concrete Structures (CSLIDE)," Instruction Report ITL-87-5, USAEWES. Available from USAEWES, 3909 Halls Ferry Road, Vicksburg, MS 39180-6199.

Price and Alling 1989

Price, W. A., and Alling, E. S. 1989. "CCHAN-Soil - Conservation Service Program STRUCHAN for Structural Design of Rectangular Channels," adapted to Corps of Engineers Structural Criteria, Technical Report ITL-89-5,

USAEWES. Available from USAEWES, 3909 Halls Ferry Road, Vicksburg, MS 39180-6199.

Los Angeles 1957

U.S. Army Engineer District, Los Angeles. 1957 (Jul). "Report on Manhole Subdrainage System: Los Angeles County Drainage Area, California." Available from U.S. Army Engineer District, Los Angeles.

U.S. Army Engineer Waterways Experiment Station 1991

U.S. Army Engineer Waterways Experiment Station. 1991 (Oct). "User's Guide: Computer Program for Design and Analysis of Sheet Pile Walls by Classical Methods (CSHTWAL)," ITL-91-1, USAEWES. Available from USAEWES, 3909 Halls Ferry Road, Vicksburg, MS 39180-6199.

U.S. Bureau of Reclamation 1974

U.S. Bureau of Reclamation. 1974. "Design of Small Canal Structures." Available from U.S. Government Printing Office, Washington, DC 20202.

Woods and Jedele 1985

Woods, R. D. and Jedele, L. P. 1985 (Oct). "Energy - Attenuation Relationships from Construction Vibrations." *Vibration Problems in Geotechnical Engineering*. Proceedings, Geotechnical Engineering Division, American Society of Civil Engineers. Available from American Society of Civil Engineers, 345 East 47th Street, New York, NY 10017-2398.

Appendix B Computer Programs

B-1. Listing

A listing and description of some of the current U.S. Army Corps of Engineers computer programs which are suitable for the structural design of elements of rectangular channels are given in Table B-1.

**Table B-1
Computer Programs**

X0022	EFFRAME	Plane Frame on Elastic Foundation (Design)
X0030	CFRAME	Interactive Graphics Plane Frame Analysis
X0031	CWALSHT	Sheet Wall Analysis/Design
X0050	CBEAMC	Analysis of Beam Column Structures with Nonlinear Supports
X0058	CUFRBC	U-Frame Basins/Channels, Design/Analysis
X0067	CASTR	Design/Investigation of Reinforced Concrete Sections
X0075	CSLIDE	Sliding Stability Analysis
X0097	CCHAN	Structural Design of Rectangular Channels
X0153	CTWALL	Analysis of Retaining Walls and Floodwalls

a. Computer Program CWALSHT. Program X0031 is suitable for the design or analysis of cantilever and anchored sheetpile walls. The program uses the classical soil mechanics procedures to determine the required depth of penetration for a new wall or to assess the factor of safety for an existing wall. Seepage effects are considered. Earth pressures are determined by input lateral soil coefficients or by the wedge method.

b. Computer Program CUFRBC. Program X0058 is suitable for design or analysis of U-frame structures. Loadings may be simple or complex. Earth pressures on walls are determined by using lateral soil coefficients, wedge solutions, or nonlinear lateral force deformation curves. The base of the structure is modeled as a beam on elastic foundation. Table B-2 is given as a guide in selecting the order of magnitude of variation in the modulus of subgrade reaction. Program CUFRBC

computes internal member loads, foundation bearing pressures and factors of safety against sliding, foundation bearing, and flotation.

**Table B-2
Values of Modulus of Subgrade Reaction for Footings / Guide for Order of Magnitude**

Soil Type	Range of k_s , kci*
Loose Sand	30-100
Medium Sand	60-500
Dense Sand	400-800
Clayey Sand (medium)	200-500
Silty Sand (medium)	150-300
Clayey Soil	
$q_u < 4$ ksf	75-150
4 ksf $< q_u < 8$ ksf	150-300
8 ksf $< q_u$	>300

*Local values may be higher or lower than the values shown.

c. Computer Program CASTR. Program X0067 is suitable for use in the design for, or investigation of, flexure in reinforced concrete beam-column sections. The program satisfies the requirements of EM 1110-2-2104 and ACI 318.

d. Computer Program CCHAN. Program X0097 is suitable for use in the design of rectangular channels. The program is adapted to four channel types; (1) reinforced concrete U-frame structures, (2) reinforced concrete retaining walls with invert pavement slab (except for thrust imposed on it by the retaining wall base), (3) reinforced concrete retaining walls with invert pavement slab and retaining wall bases designed to transmit shear forces between each other, and (4) rigid frame structure with struts at the top of the walls. Each channel type is designed for two loading conditions: (1) channel empty with backfill submerged to selected elevation and (2) channel full with backfill submerged to selected elevation. Flotation requirements are evaluated and satisfied. Earth pressures on walls are determined from the input soil coefficients.

e. Computer Program CTWALL. Program X0153 is suitable for assessing the stability of T-type retaining and flood walls in accordance with EM 1110-2-2502, ETL 1110-2-307, and ETL 1110-2-322. CTWALL will assess the overturning, sliding, and flotation stability.

Appendix C Drainage System Designs for U-frame and Trapezoidal Channels

B-1. Information Required for Seepage Analysis

a. Investigation. The scope of an investigation of subsurface soil/rock and ground water conditions for a channel project is normally influenced by the cost, complexity, and criticality of the project as well as requirements to protect adjacent development. Borings are required to determine the extent, thickness, and stratification of subsurface soils or rock along the channel project. Guidance on developing and conducting geotechnical investigations is presented in EM 1110-1-1804,* and guidance on soil sampling is presented in EM 1110-2-1907. The ground water levels along the project should be determined along with the variations in levels with the seasons of the year, rainfall, stream stage, etc. Ground water observations over an extended period of time are required to establish variations in ground water levels. General information regarding ground water levels is often available from public agencies. Specific information is best determined from long-term observations of piezometers. Piezometers to observe ground water fluctuations are not routinely installed for typical channel projects but should always be installed where drainage considerations are critical to channel performance. The use and installation of piezometers are described in EM 1110-2-1908 and TM 5-818-5.

b. Testing. The sizing of the drainage system is directly related to the amount of water entering the system which, in turn, is related to the permeabilities of the pervious strata within which the channel is constructed. The permeabilities of the pervious subsurface soils can be determined using laboratory and/or field permeability test methods. The simplest approximation method consists of visual examination and classification, and comparison with materials of known permeability. Empirical correlations are also available between grain size and permeability. Field methods include pumping tests and constant or falling head tests made in piezometers or open boreholes. EM 1110-2-1901 and TM 5-818-5 provide recommendations and procedures for determining permeability.

* References in Appendices C and D are listed in Appendix A.

c. Design requirements. The drainage system should be designed for the ground water level/stream stage which yields the critical differential head. This requires an evaluation of the variations in ground water levels coincident with variations in stream stage.

B-2. Design Example for U-Frame Channel Drainage System

a. General. Since drainage blankets are thin compared to the overall dimensions of a channel and surrounding soils, it is difficult to produce an accurate flow net within the boundaries of the drainage blankets. As stated in EM 1110-2-1901 (page 8-11), the total quantity of seepage from all sources that must discharge through drains should be evaluated from a flow net analysis in which it is assumed that the drains have an infinite permeability. To evaluate the quantity of seepage into drainage blankets for an assumed U-frame flood control channel with the foundation soil conditions shown in Figure C-1, the computer program SEEP2D (Knowles 1992, Tracy 1983, Biedenharn and Tracy 1987 (Seepage Package (x8202))) was used. The sequence of silty sand and fine sand in Figure C-1 is for alluvial conditions where permeability increases with depth. To compute seepage quantity, it was necessary to consider only the foundation soils beneath the assumed high ground water level to obtain the quantities of seepage that would flow into an inclined drainage blanket behind the wall and into a horizontal drainage blanket beneath the concrete lined channel.

b. Distance to effective source. The distance to the source of steady state seepage from the U-frame wall was taken as the radius of influence R for the silty sands and was estimated from TM 5-818-5, Figure 4-23 as

$$R = C(H - h_w)(k)^{1/2} \quad (C-1)$$

where

C = 3 for artesian and gravity flows

H = total head in feet

h_w = tailwater head in feet

k = coefficient of permeability expressed in 10^{-4} cm/sec

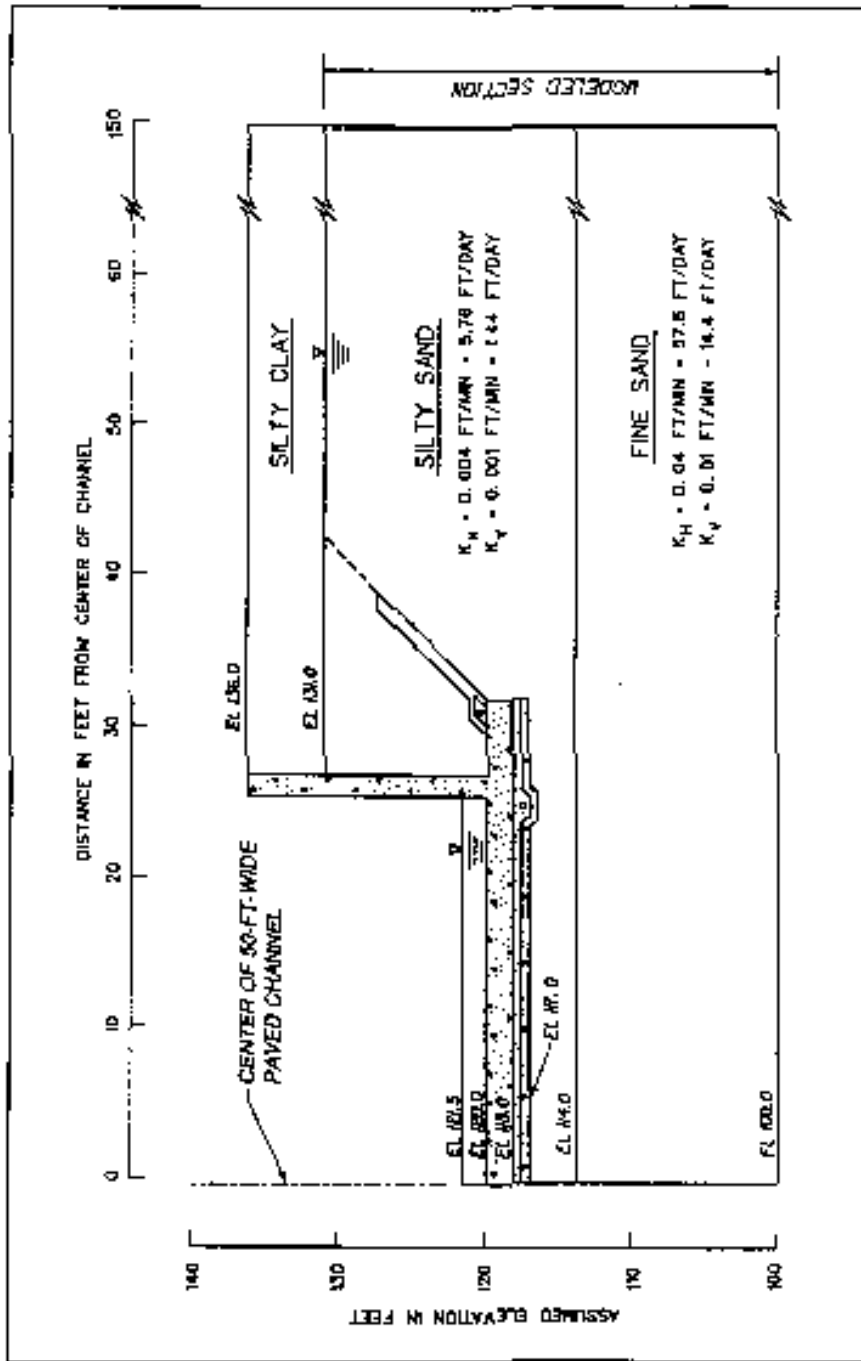

Figure C-1. Example U-frame channel and foundation conditions

The distance of half the channel width was added to R to obtain the x -coordinate. Using a value of H of 31 ft, hw of 21.5 ft, and k of 20 (without the 10-4 cm/sec), R was computed as 127 ft and the value of x (R + half the channel width) was equal to 152 which was rounded down to 150 ft. The section used for the seepage analyses with the CSEEP program package is shown in Figure C-2.

c. Seepage computer program. The seepage program package, SEEP2D, was used because it includes (1) a preprocessor program for quick definition of the problem and automatic generation of the nodes and elements; (2) a solution program for steady-state, two-dimensional seepage that automatically converges and produces a data file that includes a list of nodal points and their coordinates, elements, flows, and heads at nodal points, total inflow and total outflow, and flows and velocities for elements; and (3) a post processor program with options to produce plots of flow nets, vector diagrams, number diagrams of head or percent head, contours (equipotential lines), displaced outline, orthographic grid, or perspective grid. A graphical flow net can be obtained for problems limited to two soil types, although a listing of flows and heads can be obtained for up to 12 different soil types.

(1) Preprocessor program. The preprocessor program (X8200) requires two data files. One file is for input of boundary point coordinates, fixed or moveable points, number and spacing of intermediate node points, and material type. The other is for definition of boundary conditions with regard to head or flow, entrance or exit boundaries, and no flow boundaries. The data files for the U-frame channel example are listed in Table C-1. The preprocessor program requests an input data file name and a restart file name, then the boundary data file name and a name for the data file to be generated for use with the solution program. After module 4 is reached and PLT is entered, followed by T for total, the grid is drawn on the screen. The screen image can be saved to a file generated by the program to be printer plotted later using a program named EPRINT. The resulting grid for the example problem is shown in Figure C-3. Several trials may be needed to obtain a desirable grid.

(2) Solution program. The solution program (X8202) operates by asking for the file name from the preprocessor program and then other questions, the last of which requests names for the solution data file and file for plotting with the post processor program. In this example, a normal solution with a smooth phreatic surface and the flow net option was obtained after six iterations.

(3) Postprocessor program. The post processor program (X8201) can be used to obtain plots with axes, bigger plots, selected windows, and other types of plots. Results of the analysis are shown by a flow net in Figure C-4, a vector diagram in Figure C-5, and an elevation head plot in Figure C-6. The vector plot indicates that most of the flow will go into the base drainage blanket from the lower more permeable fine sand layer. As shown in Figure C-6, the elevation heads along the exit surface to the drainage blankets are at the tailwater elevation head of 121.5 ft except at the intersection of the phreatic surface with the inclined collector where the head is at elevation 122.01 ft.

(4) Exit flows. An extracted listing of the seepage data results from the solution program is shown in Table C-2. The first section of the table lists the node numbers and their coordinates along the exit drainage boundary, and the next section lists the node numbers, heads, percent head, outflow quantities (negative numbers), and location of the node with respect to the phreatic surface with the total inflow and total outflow listed and compared at the end. A list of the elements, element flow velocities, and vectors produced by the solution program was deleted from the data shown in Table C-2. The flows at the nodes are those for the proportional width along the boundary and correspond to the width of boundary elements. The flows are in the same kind of units used for the entered permeabilities, i.e. flows are in cubic feet per day in this example.

d. Design of drainage system. The drainage system will consist of a drainage blanket, collector drains, collector manholes, and outlet drains. The drainage blanket will consist of either one or two layers depending on whether or not one gradation of material will satisfy both the filter and drainage requirements. One collector drain will be placed behind the wall and three drains will be placed in the blanket beneath the channel bottom. One of the collector drains will be placed in the center where uplift will be most critical, and one drain will be placed along each side. Lateral drains will connect the collector drains to manholes located behind the walls. Outlet drains will discharge from the manholes into the channel.

(1) Drainage blanket. The flows into the drainage blanket from the seepage analysis are shown in Figure C-7. Total flow into the inclined drainage blanket is 6.0 cu ft/day and 43.6 cu ft/day into the base drainage blanket. These are flow rates per running foot of channel. Flow into the base drainage blanket can be divided into 16.3 cu ft/day into the center drain pipe and

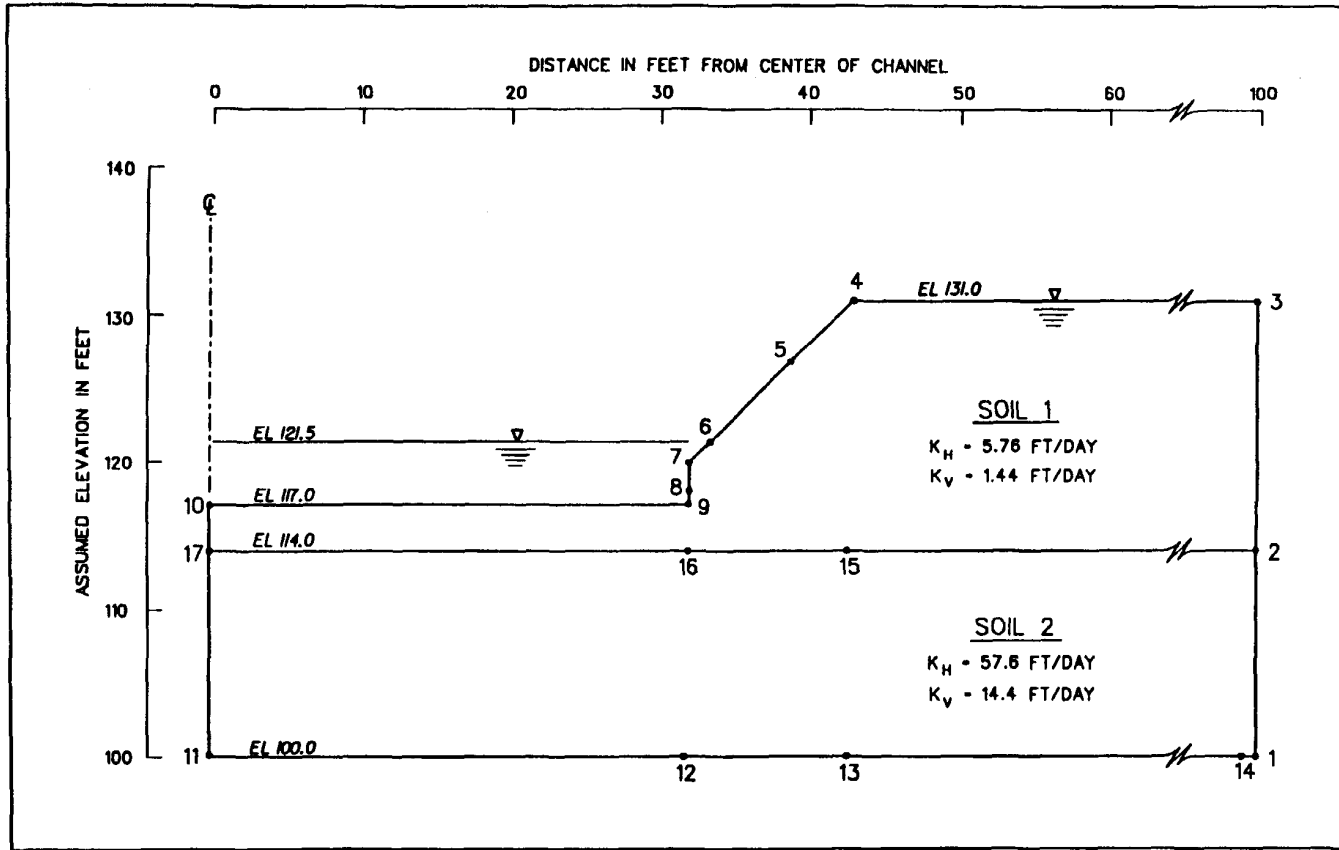

Figure C-2. Profile utilized in developing data file

Table C-1
Data Files for U-frame Channel Seepage Analysis

File UCHLLSI						File UCHLLB					
100	1	150	100			100	P	1	1	1	131.0
110	2	150	114			110	P	2	1	1	131.0
120	3	150	131			120	P	3	0	1	131.0
130	4	43	131			130	A	1	1	0	
140	5	39	127			140	P	4	1	2	121.5
150	6	33.5	121.5			150	P	5	1	2	121.5
160	7	32	120			160	P	6	0	2	121.5
170	8	32	118			170	P	7	1	1	121.5
180	9	32	117			180	P	8	1	1	121.5
220	10	0	117			190	P	9	1	1	121.5
230	11	0	100			200	P	10	0	1	121.5
240	12	32	100			210	P	17	1	0	
250	13	43	100			220	P	11	1	0	
255	14	142	100			230	P	12	1	0	
260	15	43	114			240	P	13	1	0	
265	16	32	114			250	P	15	1	0	
270	17	0	114			260	P	16	1	0	
275	-1					270	P	14	0	0	
280	1	2	F	L	4	2					
285	2	3	F	L	6	1					
290	2	15	F	L	8	2					
295	3	4	F	L	8	1					
300	4	5	F	L	1	1					
310	5	6	F	L	2	1					
320	6	7	F	L	0	1					
330	7	8	F	L	0	1					
335	8	9	F	L	0	1					
340	11	17	F	L	4	100					
350	17	10	F	L	0	100					
360	10	9	F	L	6	100					
370	11	12	F	L	6	2					
375	12	16	F	L	4	2					
380	12	13	F	L	4	2					
390	13	15	F	L	4	2					
400	13	14	F	L	7	2					
410	14	1	F	L	0	2					
420	15	4	F	L	6	1					
450	15	16	F	L	4	2					
455	17	17	F	L	6	2					
460	9	9	F	L	0	1					

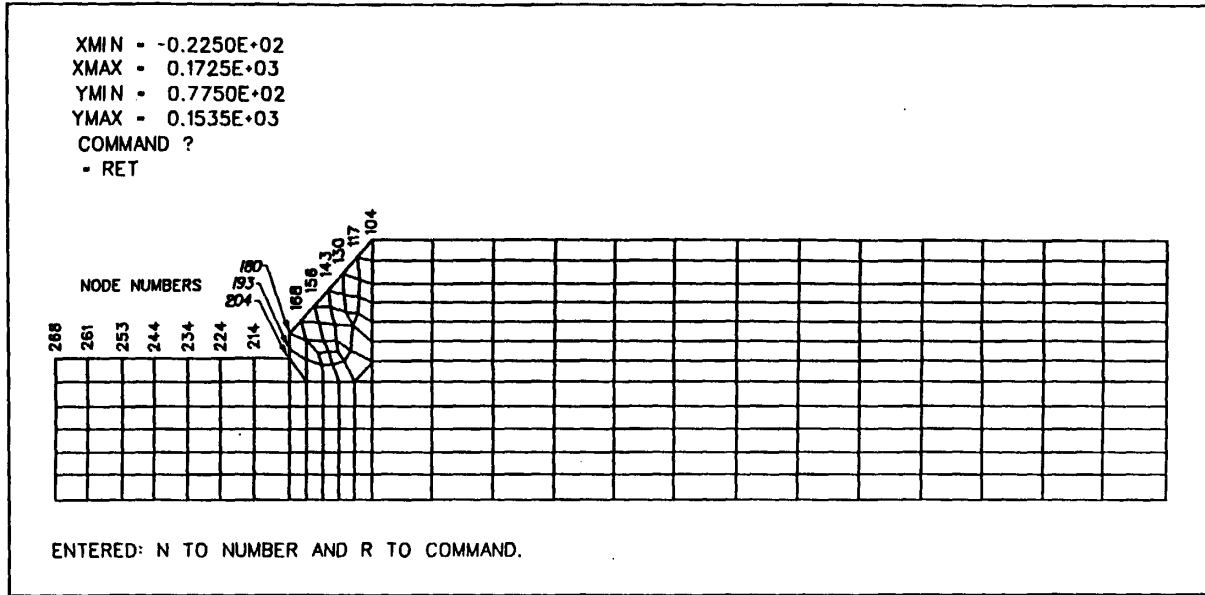

Figure C-3. Finite element grid used for analysis of U-frame channel section

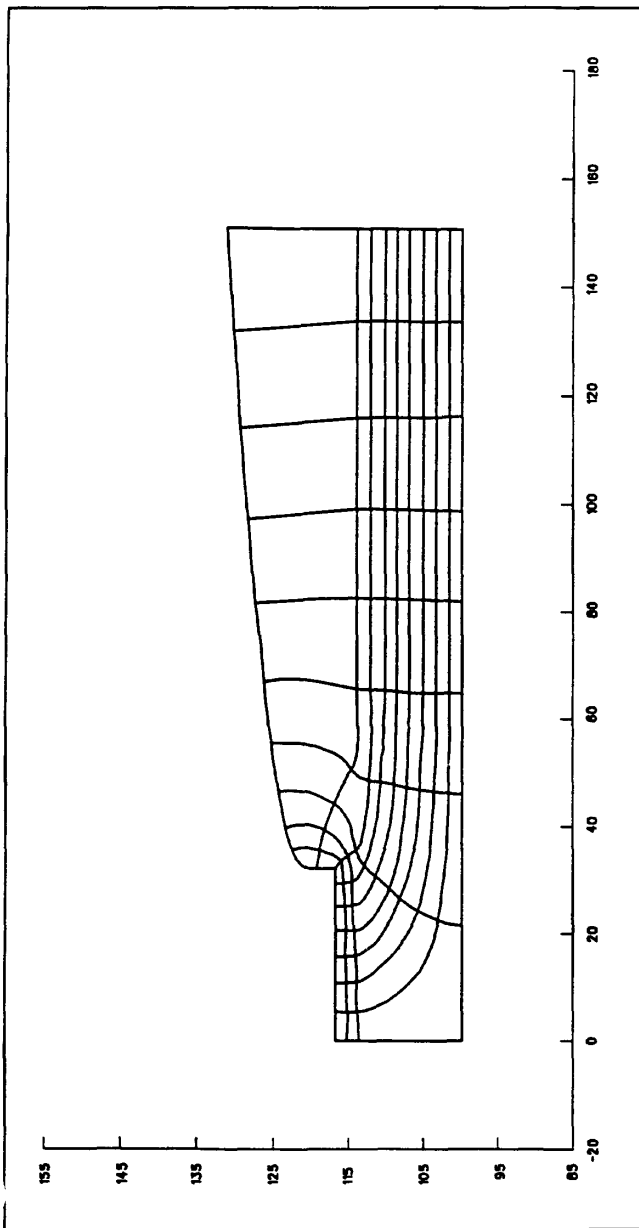

Figure C-4. Flow net from analysis of U-frame channel section

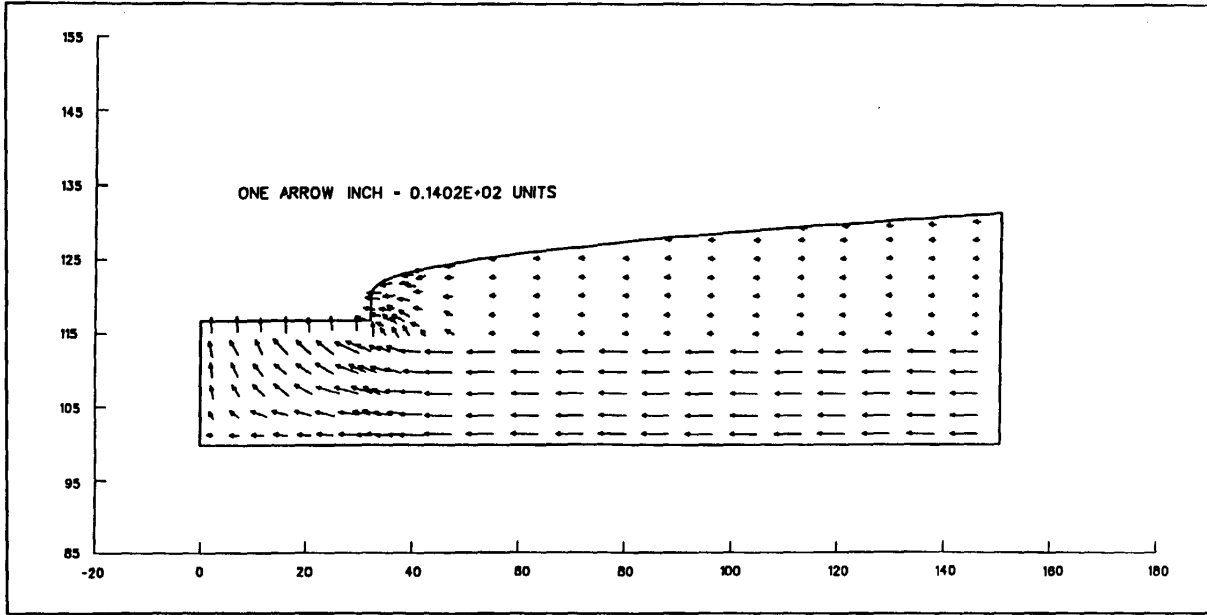

Figure C-5. Vector diagram of flow from analysis of U-frame channel section

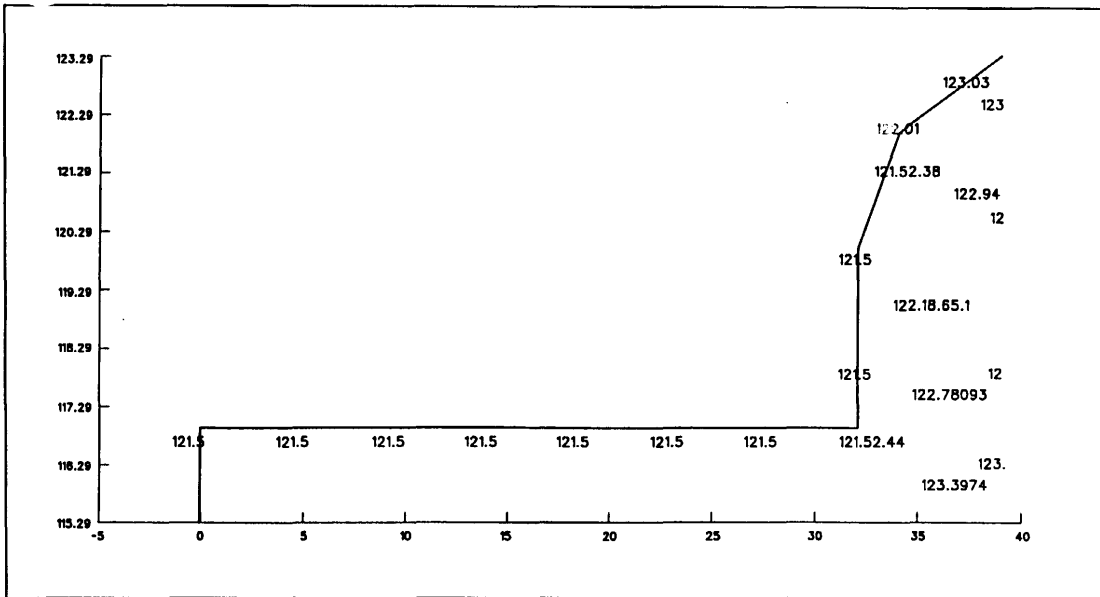

Figure C-6. Elevation head plot from analysis of U-frame channel section

Table C-2
Results of Seepage Analysis for U-Frame Channel (Continued)

U-Channel Underdrain with Inclined Wall Drain		Plane Flow Problem		
0 Number of Nodal Points-----289		0 Number of Diff. Materials-----2		
0 Number of Elements-----257		0 Elevation of Datum-----0.000		
Material Properties				
	MAT	K1	K2	
	1	0.576E+01	0.144E+01	
	2	0.576E+02	0.144E+02	
Node Point Information				
Node	BC	X	Y	Flow-Head
Sections of Listing Omitted				
104	2	43.00	131.00	121.50
117	2	41.00	129.00	121.50
130	2	39.00	127.00	121.50
143	2	37.17	125.17	121.50
156	2	35.33	123.33	121.50
168	2	33.50	121.50	121.50
180	1	32.00	120.00	121.50
193	1	32.00	118.00	121.50
204	1	32.00	117.00	121.50
214	1	27.43	117.00	121.50
224	1	22.86	117.00	121.50
234	1	18.29	117.00	121.50
244	1	13.71	117.00	121.50
253	1	9.14	117.00	121.50
261	1	4.57	117.00	121.50
268	1	0.00	117.00	121.50
Nodal Flows and Heads				
Node	Head	Percentage of Available Head		Flow
Position of Phreatic Surface				
Above	On	Below	X	Y
Parts of Listing Omitted				
141			0.1237E+03	23.1%
*			41.03	123.69
142			0.1234E+03	20.4%
*			39.40	123.44
155			0.1230E+03	16.1%
*			37.52	123.03
156			0.1220E+03	5.4
*			34.01	122.01

Table C-2 (Concluded)

Nodal Flows and Heads
(Continued)

Node	Head			Percentage of Available Head		Flow
	Above	On	Below	X	Y	
168				0.1215E+03	0.0%	-0.3816E+01
180				0.1215E+03	0.0%	-0.2220E+01
193				0.1215E+03	0.0%	-0.2731E+01
204				0.1215E+03	0.0%	-0.8623E+01
214				0.1215E+03	0.0%	-0.05624E+01
224				0.1215E+03	0.0%	-0.5260E+01
234				0.1215E+03	0.0%	-0.4996E+01
244				0.1215E+03	0.0%	-0.04803E+01
253				0.1215E+03	0.0%	-0.4669E+01
261				0.1215E+03	0.0%	-0.4591E+01
268				0.1215E+03	0.0%	-0.2282E+01
			Flow(-) =	4.9615E+01	Flow (+) =	4.9619E+01
			Flow (Ave) =		4.9617E+01	

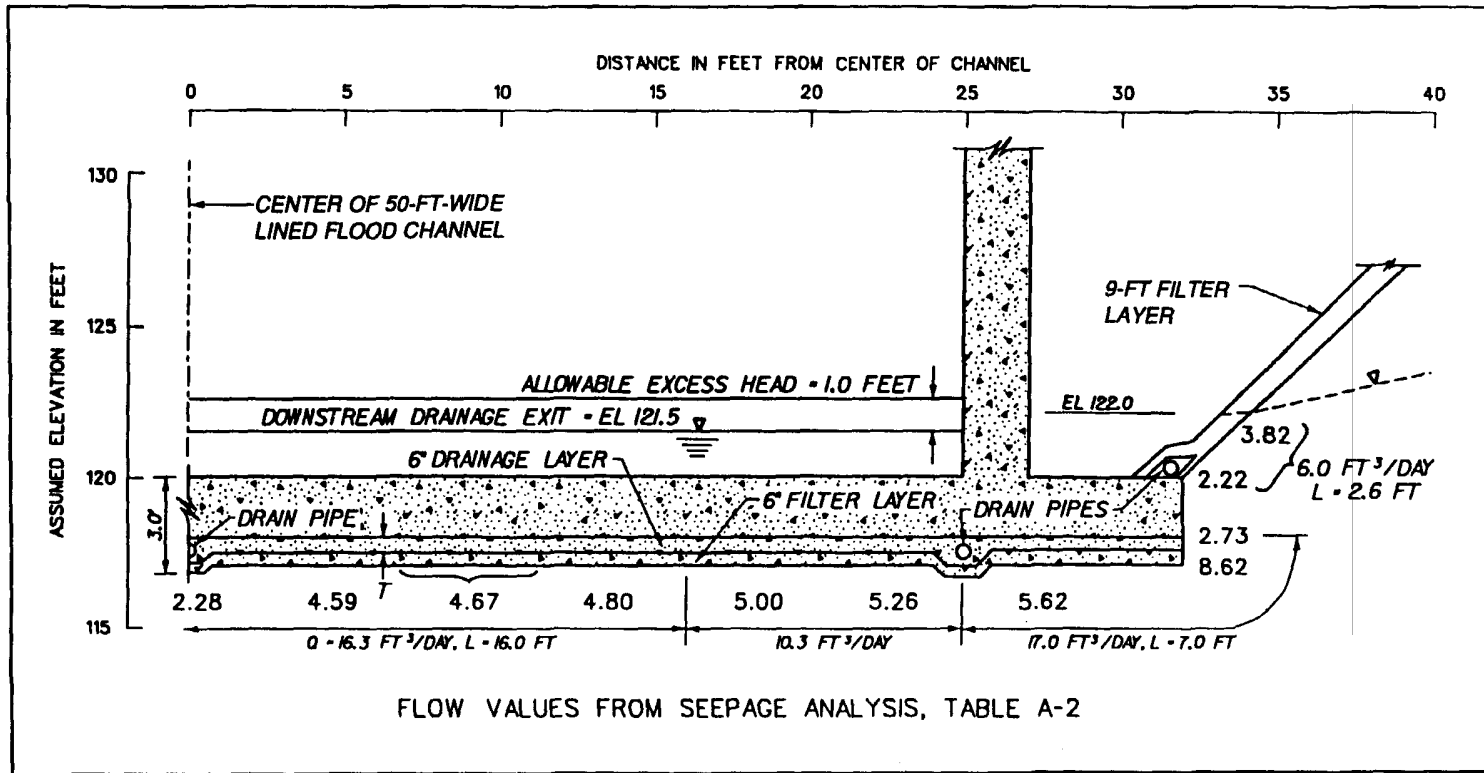

Figure C-7. Flows into drainage blanket from analysis of U-frame channel section

27.3 cu ft/day into the end drain pipes. Based on the distribution of flow to the drain pipes, the inclined drainage blanket should be designed to handle a minimum of 6.0 cu ft/day over a length of 2.6 ft and the base drainage blanket should be designed to handle a minimum of 16.3 cu ft/day into the center drain over a length of 16.0 ft. The gradation of the drainage blanket must meet the filter requirements for the natural silty sand foundation soils and also the drainage requirements. The gradation of the natural soils is represented by the grain size curve presented in Figure C-8. For this example, the gradation required to satisfy the filter criteria will be determined, and then computations will be performed to determine if the filter materials have adequate drainage capacity. If not, a two-layer drainage blanket will be required.

(a) Filter criteria. Filter criteria are presented in EM 1110-2-1901 and EM 1110-2-2502. Applying the stability and relative permeability criteria to the grain size curve for the natural foundation soils, the filter material gradations presented in Figure C-8 are obtained.

(b) Design procedure. The drainage blanket must have sufficient capacity to remove the seepage quickly without allowing high seepage pressures to develop. The variables in the blanket analysis consist of the thickness and permeability of the layer, and the permeability is in turn related to the gradations of the material. The analysis is based on Darcy's law:

$$k = \frac{Q}{iA} \quad (C-2)$$

where

k = permeability of drainage blanket

i = gradient (excess head divided by length of flow path)

A = area of blanket (thickness of blanket \times 1.0 ft of channel width)

For design, the estimated permeability of the trial drain material is multiplied by a factor of 20 (EM 1110-2-2502) to provide a reserve and account for errors in the estimated versus the actual in-place permeabilities of sands and gravels used in drainage blankets. Since the drainage blanket is horizontal, some excess differential head is required in the blanket to cause flow to the collector drain. For purposes of the analysis, it is considered that a maximum excess differential head of 1.0 ft would be allowed.

(c) Blanket thickness. The thickness of the blanket can be determined from Equation C-2, for Darcy's law, assuming the excess head of 1.0 ft so that $i = 1/L$, where L is the path length and A , the area, is the thickness $t_b \times 1.0$ for the unit length of the channel. Since

$$k_{b, \text{design}} = \frac{Q}{(1/L) \times t_b} \times 20 \quad (C-3)$$

then

$$t_b = \frac{Q \times L \times 20}{k_{b, \text{design}}} \quad (C-4)$$

(d) Base drainage blanket. The first trial considers using the filter material to satisfy also the drainage requirements. The filter materials are estimated to have a permeability of 1.0 ft/min (TM 5-818-5, Table 3-4) or 1,440 ft/day. The blanket thickness for a permeability of 1,440 ft/day, a Q of 16.3 cu ft/day and a drainage-path length of 16 ft is equal to

$$t_b = \frac{16.3 \times 16 \times 20}{1,440} = \frac{5,216}{1,440} = 3.62 \text{ ft or } 43.5 \text{ in.}$$

Obviously, this thickness is not feasible and a two-layer drainage blanket will be required. A 3/8 in. to No. 4 sieve gravel has an estimated permeability of 8,000 ft/day (Cedegren 1989, Table 2.1). The thickness required for this permeability is

$$t_b = \frac{5,216}{8,000} = 0.652 \text{ ft or } 7.8 \text{ in.}$$

which is rounded to 9 in. for a design thickness. For this thickness the design permeability would be

$$k_{b, \text{design}} = \frac{16.3 \times 16 \times 20}{9/12} = 6,955 \text{ ft/day}$$

The permeability value of 6,955 ft/day is rounded to 7,000 ft/day. To check for decrease in permeability caused by turbulence, the value of i ($1/16 = 0.0625$) and the effective size (0.3 in.) are used with Figure 6-9 from EM 1110-2-2502 to obtain a reduction factor. In this case, the factor is equal to 0.8 and the reduced

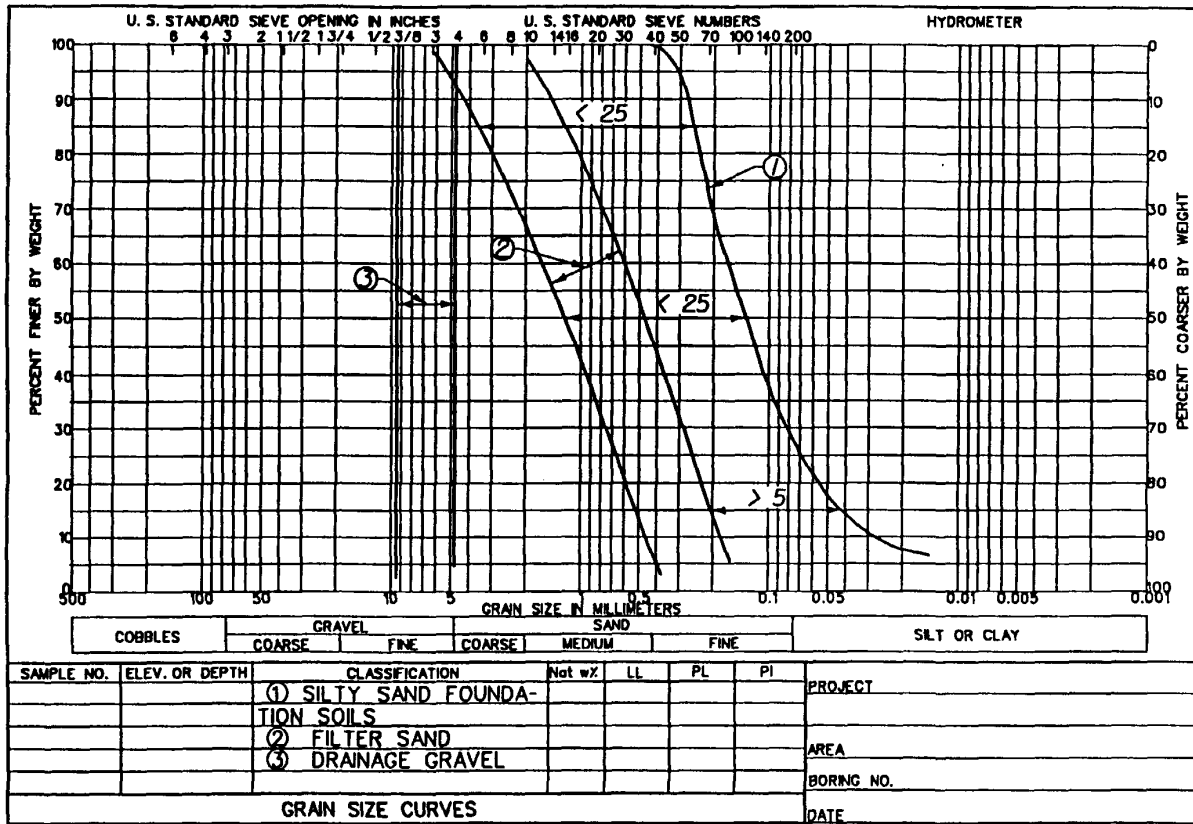

ENG FORM 2087
1 MAY 83

Figure C-8. Gradation of drainage materials for U-frame channel section

permeability is $0.88 \times 8,000$ or 7,040 ft/day which is greater than the design value of 7,000 ft/day. Therefore, a two-layer drainage blanket consisting of 6 in. of filter sand and 9 in. of 3/8 in. to No. 4 sieve gravel should be used.

(e) Collector pipe. The center collector pipe will have a flow of 32.6 cu ft/day per linear foot of pipe (2×16.3 cu ft/day). Assuming manholes located behind the walls at 250-ft intervals, the accumulated discharge of the pipe will be 8,150 cu ft/day ($250 \text{ ft} \times 32.6 \text{ cu ft/day/ft}$). The pipe size is estimated from the airfield drainage nomograph presented in Figure C-9 which requires flow in cubic feet per second and slope of the pipe. A flow of 8,150 cu ft/day is equal to 0.09 cu ft/sec. Considering a small slope of $s = 0.0008$ or 0.08 ft/100 ft, a 5-in.-diam pipe could be used. However, the minimum allowed is 6-in. diam. The opening sizes in the collector pipe should be determined using the following criteria.

Circular openings:

$$\frac{D_{50_f}}{\text{Hole Diameter}} > 1.0 \quad (\text{C-5})$$

Slotted Openings:

$$\frac{D_{50_f}}{\text{Hole Diameter}} > 1.2 \quad (\text{C-6})$$

Place 6-in. minimum thickness gravel layer around collector pipes. Use gravel having a 50 percent size of 3/8 in. and use 3/8-in. circular openings in collector pipe.

(3) Inclined drainage blanket. An excess head of 0.5 ft occurs at the inclined drain and the design k value for a filter blanket thickness of 9.0 in. is:

$$k_{b_{\text{design}}} = \frac{6.0 \times 2.6 \times 20}{0.5 \times 0.75} = 832 \text{ ft/day}$$

The filter material to be used below the base has an estimated permeability of 1,440 ft/day and should satisfy both the filter and drainage requirements for the inclined blanket. For this low Q and k , the minimum required collector pipe diameter size of 6 in. would be more than adequate.

(4) Manholes. Manholes behind the U-frame wall would be needed at 250-ft intervals. Outlet drains

through the wall should be provided with check valves to prevent backflow into the drainage system.

3. Design Example for Trapezoidal Channel Drainage System

a. General. The trapezoidal channel example section is shown in Figure C-10. This example depicts deep alluvial fine sands that could produce large drainage quantities. A 100-ft-wide channel with a 2-ft-thick concrete lining was assumed. The distance to the steady state seepage source was estimated to be 625 ft from the center of the channel using the radius of influence Equation, C-1, described earlier. The head at the source was assumed to be at elevation 115 ft, and the head for drainage of the collector pipes into manholes was assumed to be at elevation 101.5 ft at the channel. The permeability of the sand was assumed to be 20×10^{-4} or 57.6 ft/day with a 4:1 ratio of horizontal to vertical permeability.

b. Seepage analyses. The SEEP2D program was used to determine the flow exiting from the silty sand foundation into the drainage and/or filter layer(s). The analysis was performed in the same manner as described

$\frac{Q}{20.8}$	$\frac{L}{29}$	$\frac{Q \times L}{603}$	$\gg \gg \gg$	$t_b = \frac{20.8 \times 29 \times 20}{576}$
17	21	357		$t_b = 20.9 \text{ ft}$
36.9	12	443		

for the U-frame channel in the previous example. The data files are listed in Table C-3 and an abbreviated listing of the tabular results from the analysis is shown in Table C-4.

c. Design of drainage system. The flows out of the foundation that would enter the drainage and/or filter layer(s) are shown in Figure C-11. Collector pipes are assumed to be located at the center and on each side of the channel in the drainage blanket. The flow is divided into segments for each collector pipe as shown in Figure C-11, and the design permeability is determined for the largest $Q \times L$ combination using Equation C-3. The calculations shown below indicate that an open graded gravel drainage layer and filter layer would be required.

(1) Drainage blanket. Using Q and L from the largest $Q \times L$ value and an excess head of 1.0 ft, the drainage

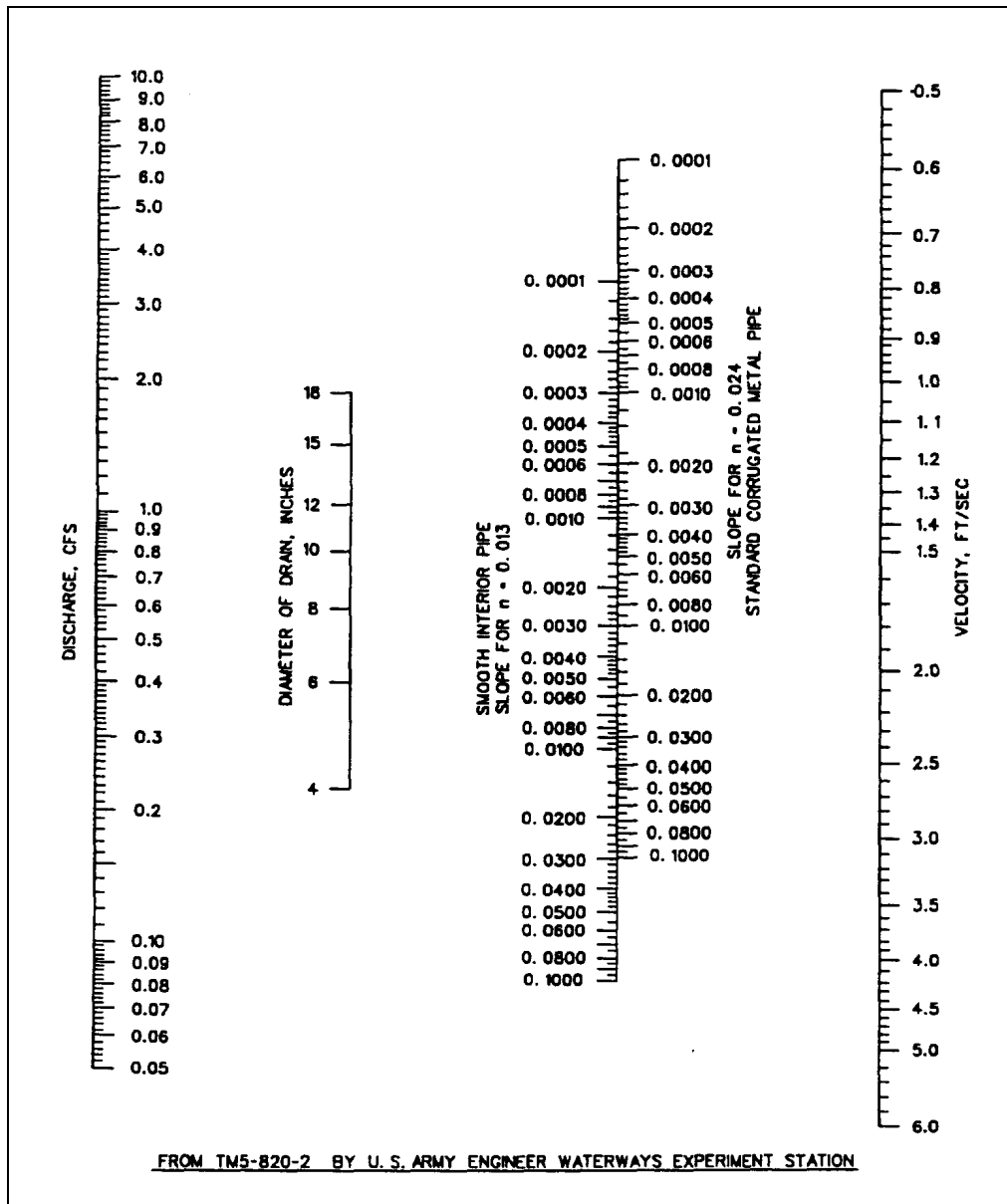

Figure C-9. Airfield drainage nomograph for computing required size of circular drain, flowing full

blanket thickness was determined for the coarse to medium filter sand shown in Figure C-10. The permeability of the filter sand is assumed to be 0.40 ft/min (TM 5-818-5, Table 3-4) or 576 ft/day. Using Equation C-4:

The thickness of 20.9 ft is unreasonable and a drainage layer and filter layer are needed. The design permeability from Equation C-3 is:

$$k_{b, \text{design}} = \frac{20.8 \times 29 \times 20}{0.5} = 24,128 \text{ ft/day}$$

Adequate drainage could be obtained using 3/8- to 1/2-in. open graded gravel with $k = 30,000$ ft/day (Cedegren 1989).

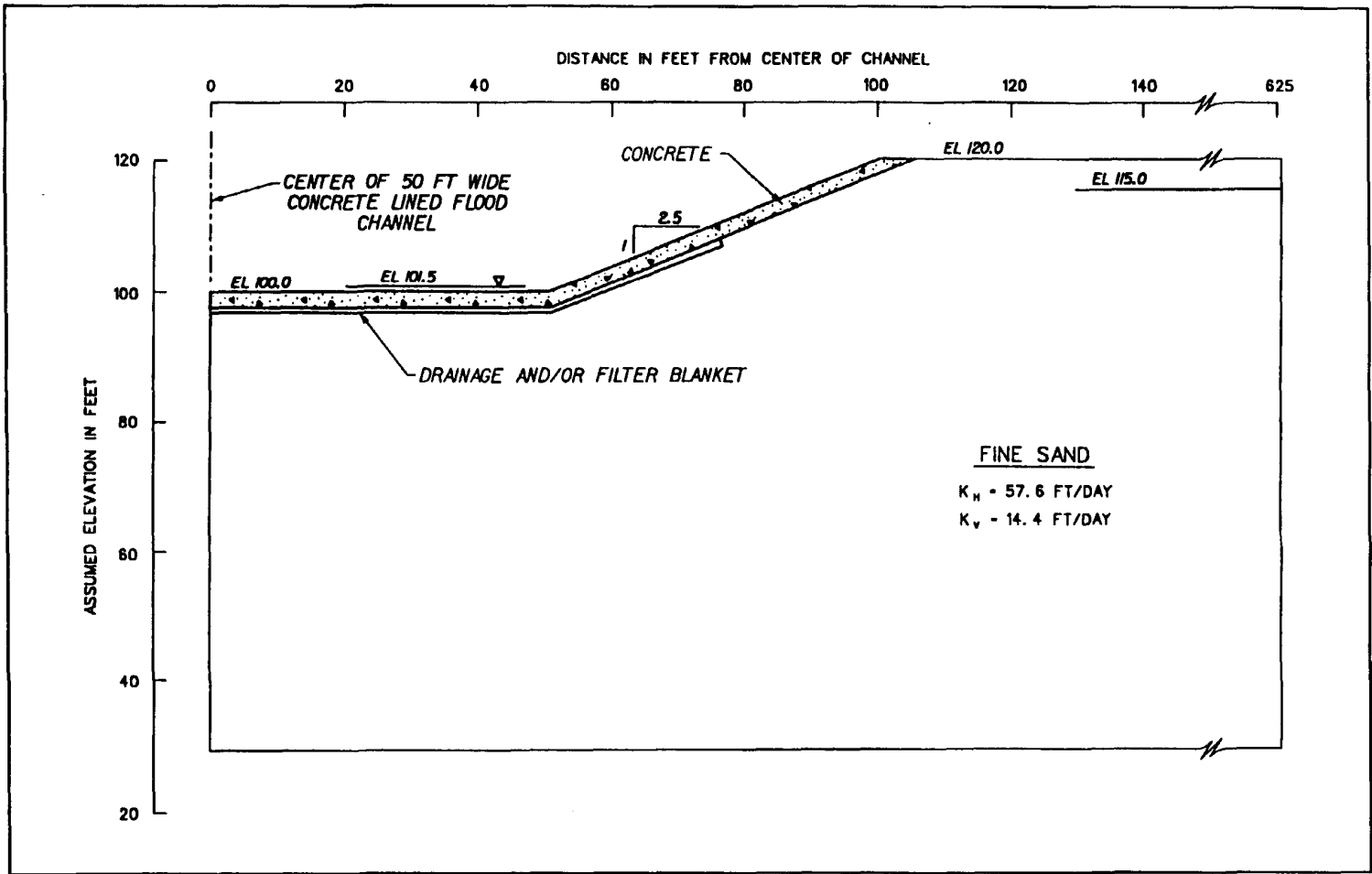

Figure C-10. Example trapezoidal channel and foundation conditions

Table C-3
Data Files for Trapezoidal Channel Seepage Analysis

File TCHNUI						File TCHNUB					
100	1	625	30			100	P	1	1	1	115
110	2	625	97			110	P	2	1	1	115
120	3	625	115			113	P	3	0	1	115
130	4	87.5	115			115	A	1	1	1	
140	5	75	110			120	P	4	1	2	115
150	6	76.1	107.2			130	P	5	1	2	110
155	7	61.8	101.5			135	P	6	1	2	107.2
160	8	50.6	97			140	P	7	0	2	101.5
170	9	0	97			145	A	1	1	1	101.5
180	10	0	30			150	P	8	1	1	101.5
190	11	50.6	30			160	P	9	0	1	101.5
200	12	87.5	30			170	A	1	1	0	
210	13	87.5	97			190	P	10	1	0	
220	14	608	30			210	P	11	1	0	
230	-1					220	P	12	1	0	
240	1	2	F	L	7	1	230	P	13	1	0
250	2	3	F	L	2	1	240	P	14	0	0
260	3	4	F	L	30	1					
265	9	8	F	L	5	100					
270	8	7	F	L	1	100					
280	7	6	F	L	1	100					
290	6	5	F	L	0	100					
300	5	4	F	L	1	100					
320	9	10	F	L	7	1					
330	10	11	F	L	5	1					
340	11	8	F	L	7	1					
350	11	12	F	L	5	1					
360	12	13	F	L	7	1					
370	12	14	F	L	29	1					
380	14	1	F	L	0	1					
390	13	4	F	L	2	1					
400	13	8	F	L	5	1					
410	13	2	F	L	30	1					

Table C-4
Results of Trapezoidal Channel Seepage Analysis (Continued)

Plane Flow Problem					
Trapezoidal Channel, Lined to Midheight of slope, 1V on 2.5H					
0 Number of Nodal Points-----499		0 Number of Diff. Materials----- 1			
0 Number of Elements-----451		0 Elevation of Datum----- 0.000			
Material Properties					
	MAT	K1	K2		
	1	0.576E+02	0.144E+02		
Node Point Information					
Node	BC	X	Y	Flow-Head	
Parts of Listing Omitted					
375	2	61.80	101.50	101.50	
387	1	56.20	99.25	101.50	
397	1	50.60	97.00	101.50	
408	1	42.17	97.00	101.50	
419	1	33.73	97.00	101.50	
430	1	25.30	97.00	101.50	
441	1	16.87	97.00	101.50	
451	1	8.43	97.00	101.50	
461	1	.00	97.00	101.50	
Nodal Flow and Heads					
Node	Head	Percentage of Available Head		Flow	
Position of Phreatic Surface					
Above	On	Below	X	Y	
Parts of Listing Omitted					
341			0.1028E+3	905%	
*			80.62	102.84	
353			0.1026E+03	8.2%	
*			75.69	102.60	
364			0.1019E+03	3.3%	
*			62.91	101.94	
375			0.1015E+03	0.0%	-0.2410E+02
	*				
387			0.1015E+03	0.0%	-0.1276E+02
	*				
397			0.1015E+03	0.0%	-0.1756E+02
	*				
408			0.1015E+03	0.0%	-0.9852E+01
	*				
419			0.1015E+03	0.0%	-0.8252E+01
	*				
430			0.1015E+03	0.0%	-0.7364E+01
	*				
441			0.1015E+03	0.0%	-0.6850E+01
	*				

Table C-4 (Concluded)

Nodal Flow and Heads(Continued)						
Node		Head		Percentage of Available Head		Flow
Position of Phreatic Surface				X	Y	
Above	On	Below				
451		*		0.1015E+03	.0%	-0.6548E+01
461		*		0.1015E+03	.0%	-0.3264E+01
		Flow (-) =		9.6552E+01	Flows (+) =	9.6169E+01
				Flow (Ave) =	9.6361E+01	

(2) Collector pipe. The collector pipe along the edge of the channel will have the maximum computed flow of 53.9 cu ft/day/ft of length (17.0 cu ft/day + 36.9 cu ft/day). Locating manholes on 500- ft intervals yields an accumulated discharge of 26,950 cu ft/day or 0.31 cu ft/sec. Based on Figure C-11 and using a slope of 0.10 ft/100 ft, a 9-in. diam pipe would be required. The opening sizes in the pipe would need to be 3/8 in. considering equation B-5 and the 3/8- to 1/2-in. open graded gravel to be used for the drain material. For this opening size and drain material, a specified filter gravel would not be required around the collector pipe as was required in the previous example.

(3) Filter layer. A filter layer is needed to protect against migration of the foundation sands into the gravel drainage blanket. A medium to coarse sand will satisfy the filter requirements, as shown in Figure C-12.

(4) Manholes. Manholes to collect and dispose of the upstream drainage would be spaced at about 500-ft intervals along the collector pipe at the toe of the channel slope. Laterals would be required between the collector pipe down the center of the channel and the manholes.

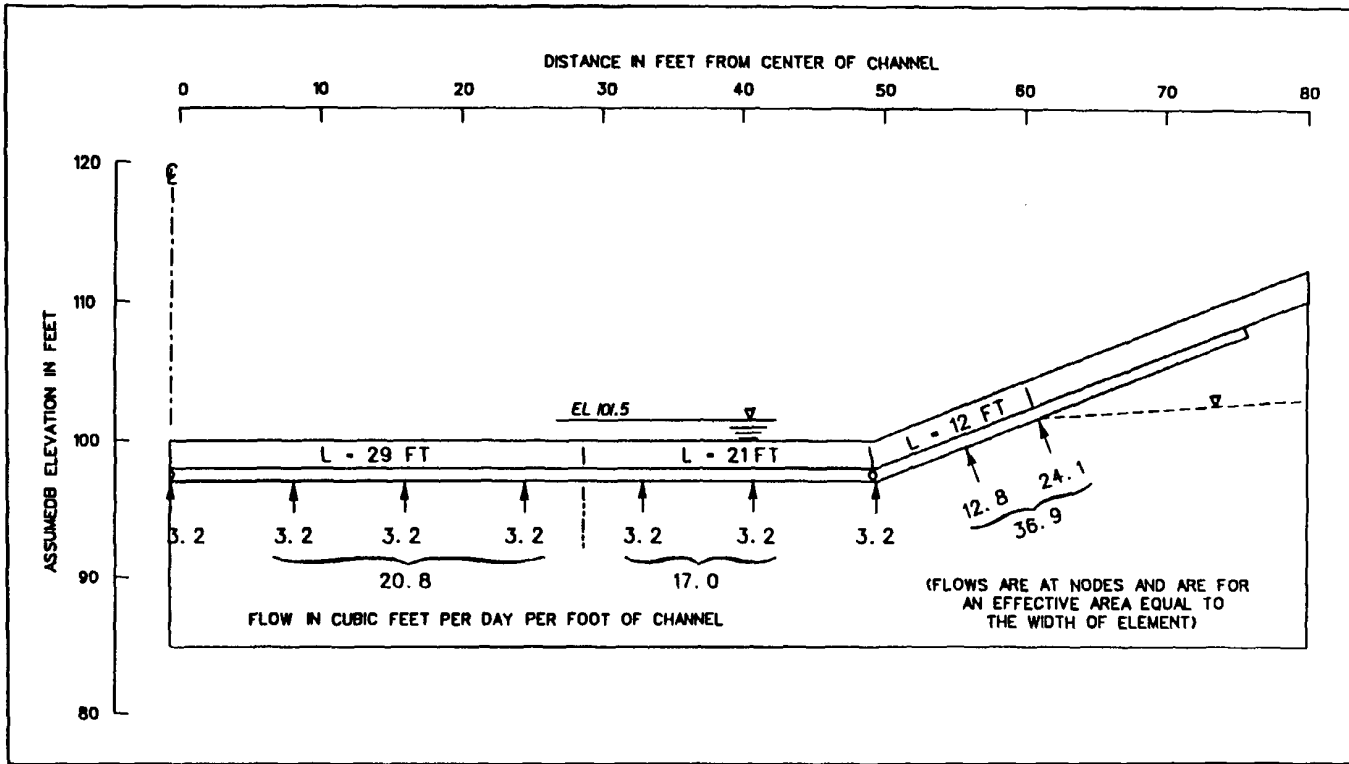
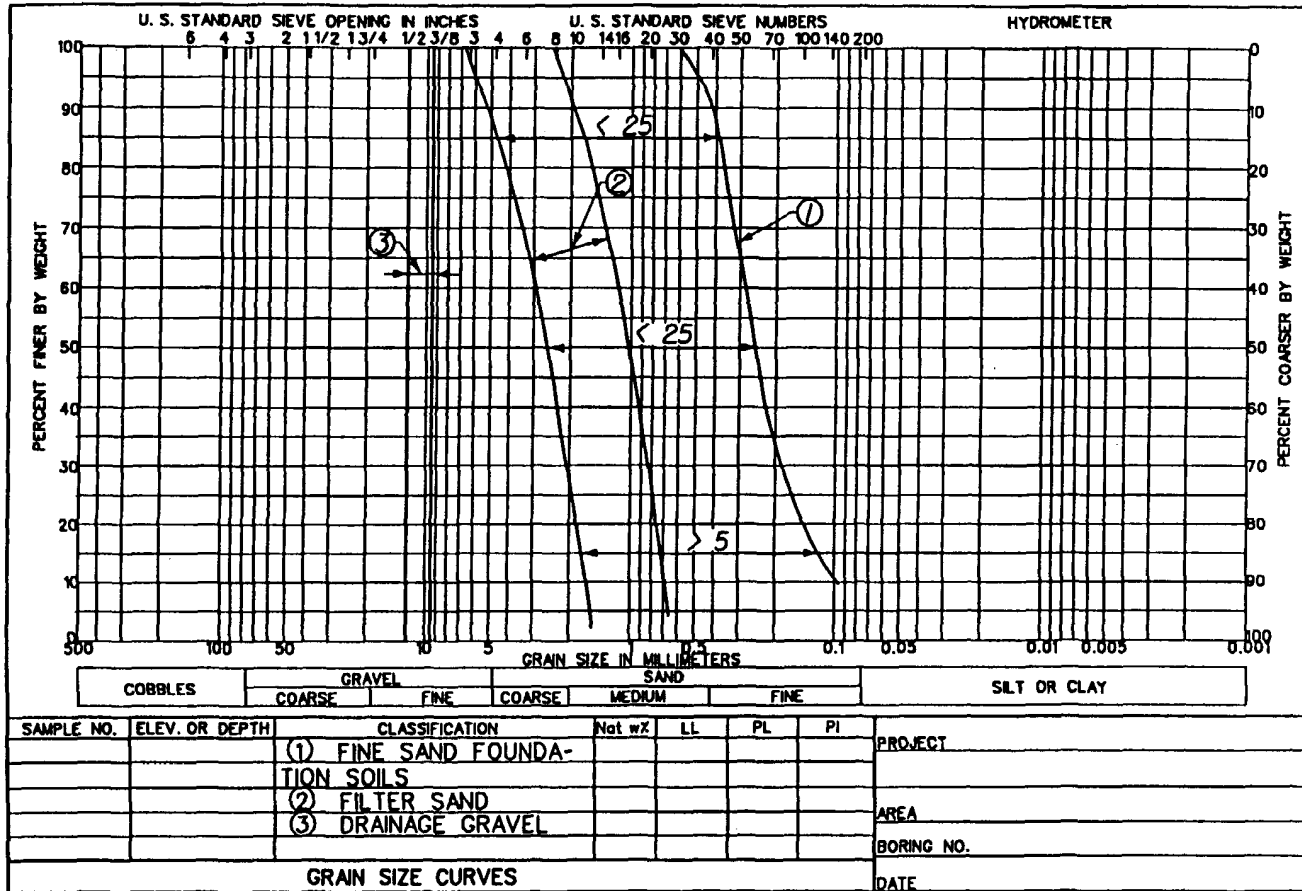

Figure C-11. Flows into drainage blanket from analysis of trapezoidal channel section



ENG FORM 2087
1 MAY 83

Figure C-12. Gradation of drainage materials for trapezoidal channel section

Appendix D Equations for Continuously Reinforced Concrete Pavement

The following equations for selecting the design reinforcement for continuously reinforced highway and airfield paving were taken from TM 5-825-3, Chapter 5.

$$P_1 = (1.3 - 0.2F) \frac{100f_t}{f_s} \quad (D-1)$$

$$P_1 = \frac{100f_t}{2(f_s - \nabla T n_c E_s)} \quad (D-2)$$

$$P_1 = \frac{100f_t}{f_s} \quad (D-3)$$

where

P_1 = percent of reinforcing steel required in the longitudinal direction

F = friction factor of the supporting soil (1.5 is suggested unless value is known)

f_t = the 7-day tensile strength of the concrete using the splitting tensile strength; for concrete strengths of 25 MPa (3,000 psi) at 28 days, the value of f_t may be taken as 2 MPa (230 psi)

$$f_t' = 0.45(6.5)(1.5) \sqrt{3,500} = 230 \text{ psi}$$

f_s = working stress of reinforcing steel, 75 percent of the tensile yield strength of the steel. This produces a safety factor of 1.33

∇T = seasonal temperature variation

n_c = thermal coefficient of expansion of the concrete

E_s = modulus of elasticity of steel